

South Plains Community Action Association, Inc.
SPARTAN Public Transit

Request for Proposals for Transit Fleet Vinyl Wrap Design and Installation



806-894-3800
spartanpublictransit.com
1105 W Hwy 114, Levelland, Tx 79336

Table of Contents

Timetable of RFP Events.....	2
General Specifications	3
Request.....	3
Purpose.....	3
Geographic Preference Prohibition	3
Submission Requirements	3
Contact Person.....	4
Contract Type.....	4
Timeline.....	4
Limitations and Reservations	4
Modification and Renewals	4
Signatures	5
Evaluation Criteria	5
Protest Rights.....	5
Conflict of Interest.....	5
Subcontracting.....	5
Availability of RFP.....	5
Business Conduct	6
Practice of Ethical Behavior	6
Public Notice	7
Specifications Criteria.....	8
Certification of Compliance with Specifications.....	9
Program Narrative Requirements	10
Proposed Price/Cost.....	11
Assurances	12
Certifications Regarding Lobbying, Debarment, Suspension and Other Responsibility Matters..	13
Evaluation Table and Proposal Rating Summary.....	15
Addendum A	16
Rough Draft Sketches	17
Elevation Drawings	21
TxDOT Form PTN-130	43

Timetable of RFP Events

Action	On
Public Media Notification of RFP	March 9, 2025
RFP Available for Distribution	March 7, 2025
Deadline for Questions Regarding RFP	March 14, 2025
Answers Provided to RFP Questions	March 18, 2025
Proposal Submission Deadline	March 21, 2025
Review and Evaluation Process Begins	March 24, 2025
Selection and Negotiation with Winning Proposer	March 26, 2025
Contract Execution and Service Initiation	April 7, 2025

General Specifications

Request

South Plains Community Action Association, Inc. (SPCAA) through its division, SPARTAN Public Transportation, is seeking proposals from qualified vendors to provide professional vehicle wrapping services for approximately 40 vehicles. The selected vendor will be responsible for creating vector files, refining provided rough sketches in the final artwork, producing and installing high-quality vinyl wraps, and ensuring compliance with all applicable standards and certifications.

Purpose

The purpose of this Request for Proposals (RFP) is to solicit competitive proposals from qualified vendors to design, produce, and install vinyl wraps for SPARTAN Public Transportation's fleet of vehicles. This project aims to enhance SPARTAN's brand visibility, ensure a uniform and professional appearance across all fleet vehicles, and provide durable, high-quality wraps that meet industry standards. The successful vendor will be responsible for all aspects of the design, production, and installation process, ensuring seamless integration with SPARTAN's existing fleet specifications.

Geographic Preference Prohibition

SPCAA shall conduct procurements in a manner that does not give in-state or local geographical preferences in the evaluation of bids or proposals, except in those cases where applicable Federal Statutes expressly mandate or encourage geographic preference. This does not preempt State Licensing Laws. Geographic location may be a selection criterion in procurements for architectural and engineering (A&E) services if an appropriate number of qualified firms, given the nature and size of the project, are able to compete for the contract.

Submission Requirements

Proposals must be formatted according to the following structure:

1. **Cover Letter:** A brief introduction and summary of the vendor's capabilities.
2. **Company Information:** Legal business name, contact details, and relevant certifications.
3. **Experience & References:** Summary of relevant experience and three references from similar projects.
4. **Technical Proposal:** Detailed response to the Scope of Work.
5. **Cost Proposal:** Detailed breakdown of pricing as outlined on pg.11.
6. **Certifications & Assurances:** Compliance with PTN-130 (pg.43) and other required forms completed, dated, and signed where applicable.
7. **Insurance Documents:** Proof of liability insurance, workers' compensation, and vehicle coverage.

8. **Proposal Submission:** Proposal must be electronically received by March 21, 2025.

Contact Person

All questions concerning this RFP packet should be emailed to: Ms. Megan Riddle at mriddle@spscaa.org. Questions and answers will be posted at www.spartanpublictransit.com under the "Business W/SPARTAN" tab.

Contract Type

The winning proposal will be offered a standard agreement/contract from South Plains Community Action Association, Inc.

Timeline

The successful Proposer agrees to begin providing services within 30 consecutive business days (Monday – Friday) from agreement/contract negotiation notice. Should the work not begin within the specified time, vendor negotiations may be terminated.

Limitations and Reservations

South Plains Community Action Association, Inc. reserves the right to accept or reject any and all proposals received as a result of this request, to negotiate with all qualified sources, to award all or part of services to one or multiple vendors, or to cancel in part or in its entirety this RFP, if found to be in the best interests of SPCAA.

This RFP does not commit SPCAA to award a contract, to pay any costs incurred for the preparation of proposals or to procure or contract for any services.

SPCAA specifically reserves the right to vary the provisions set forth herein at any time prior to the execution of contract where such variance is deemed to be in the best interest of the SPCAA. While every effort has been made to ensure the accuracy and completeness of the information in this RFP, SPCAA recognizes that the information is not exhaustive in every detail and that all work and materials may not be expressly mentioned in the requirements of the RFP. Therefore, it is the responsibility of the Contractor to include in their proposal all software and hardware (if applicable) requirements which are necessary for the full performance of the system.

If selected for negotiations, the Proposer(s) may be required to prepare and submit additional information prior to final vendor(s) selection, to reach terms for the provision of services, which are agreeable to both parties.

Proposals not meeting the submission requirements listed below will be considered ineligible.

Modification and Renewals

SPCAA reserves the right to modify or renew the awarded contract as necessary to meet operational requirements. Modifications may include, but are not limited to, adjustments in project scope, pricing, or service timelines. Any contract renewal or modification must be agreed upon in writing by both parties, if applicable. Renewals will be based on satisfactory performance, funding availability, and the ongoing need for vinyl wrapping services.

Signatures

A proposal shall be signed by the business's official authorized individual(s) to bind that business and shall contain a statement to the effect that the proposal is a firm bid for a 30-day period from the date that the proposal is received by SPCAA. The proposal shall also provide the name, title, address, and telephone number of the individual(s) with authority to negotiate during the period of proposal evaluation.

Evaluation Criteria

The selection of a proposal is to be made after careful evaluation of the proposals received. Each proposal will be evaluated for acceptability with emphasis on the various factors enumerated in the EVALUATION TABLE (pg.15). Each factor is assigned a numerical score. The scores will be used to determine vendor(s) with whom negotiations may be conducted. Evaluations will be based upon the following criteria table for which up to 100 points may be awarded. Total evaluation values of less than 70 points will invalidate a proposal.

Protest Rights

Any bidder may file a grievance with SPCAA following a competitive bidding process. Once a selection is made, bidders must be notified in writing of the results. The written communication mailed to bidders must also inform them that they may have a right to appeal the decision.

Information on the organization's appeal procedures must be made available to all prospective contractors or subgrantees upon request, including the name and address of a contact person, and a deadline for filing the grievance. Grievances are limited to violations of federal laws or regulations, or failure of the Organization to follow its own procurement policies.

Grievances can be mailed to the following address:

SPCAA
PO Box 610
Levelland, Tx 79336

Conflict of Interest

To avoid any real or apparent conflict of interest in the procurement of this RFP, no SPCAA employee or their family member may vote on or financially benefit from any award connected with this request.

Subcontracting

The services of any vendor(s) awarded from this RFP must be delivered by the vendor named in the proposal. Subcontracting will not be allowed unless prior authorization from SPCAA is given. HUB/DBE/SBE participation is encouraged.

Availability of RFP

To obtain a copy of the RFP, please visit www.spartanpublictransit.com and navigate to the "Business W/SPARTAN" tab. Hard copies of the RFP will be available to pick up at 1105 W Hwy 114, Levelland, Tx 79336.

Business Conduct

Practice of Ethical Behavior

SPCAA requires board members, committee members, and employees to observe high standards of business and personal ethics in the conduct of their duties and responsibilities, and all directors, committee members, and employees to comply with all applicable laws and regulatory requirements. Unethical actions, or the appearance of unethical actions, are unacceptable under any conditions.

The policies and reputation of SPCAA depend, to a very large extent, on the following considerations.

Each employee must apply their own sense of personal ethics, which should extend beyond compliance with applicable laws and regulations in business situations, to govern behavior where no existing regulation provides a guideline. Each employee is responsible for applying common sense in business decisions where specific rules do not provide all the answers.

In determining compliance with this standard in specific situations, employees should ask themselves the following questions:

1. Is my action legal?
2. Is my action ethical?
3. Does my action comply with SPCAA?
4. Am I sure my action does not appear inappropriate?
5. Am I sure that I would not be embarrassed or compromised if my action became known within the Organization or publicly?
6. Am I sure that my actions meet my personal code of ethics and behavior?
7. Would I feel comfortable defending my actions on the 6 o'clock news?

Each employee should be able to answer "yes" to all these questions before acting.

Each director, supervisor, and manager are responsible for the ethical business behavior of their subordinates. Directors, supervisors, and managers must carefully weigh all courses of action suggested in ethical, as well as economic, terms and base their final decisions on the guidelines provided by this policy, as well as their personal sense of right and wrong.

March 9, 2025

Attn: Public Notices
Levelland & Hockley County News-
Press 806-894-3121

Fr: Megan Riddle
SPCAA-SPARTAN
806-894-3800

Public Notice

**South Plains Community Action Association, Inc.
SPARTAN Public
Transit Request for
Transit Fleet Vinyl
Wrap, Design, and
Installation**

SPCAA SPARTAN Public Transportation is accepting proposals from qualified sources for transit fleet vinyl wrap, design, and installation. To obtain a copy of the RFP with specifications please visit www.spartanpublictransit.com and navigate to the "Business W/SPARTAN" tab. Proposals must be received by March 21, 2025.

Proposals should be submitted electronically to mriddle@spscaa.org.

Specifications Criteria

This is a Request for Proposal for a complete fleet vinyl wrap design and installation. Additional information regarding the enumerated list below may be found in Addendum A (pg.16). All interested parties should submit the following information to be considered responsive as well as demonstrate their capabilities to provide, perform, and complete the following task.

1. Develop vector-based designs from SPARTAN's provided sketches.
2. Provide cost-effective solutions for vehicle wrap production.
3. Use high-quality, durable vinyl materials.
4. Offer pricing per vehicle type.
5. Ensure proper installation and fit for various bus models.
6. Provide warranties for materials and labels, specifying the proposed vinyl type and it's estimated useful life. SPARTAN retains vehicles for an average of 5-7 years.
7. Remove existing wraps if necessary.
8. Provide appropriate Business Certifications and TxDOT Form PTN-130.
9. Please state if the proposed business is a HUB/DBE/SBE.

Certification of Compliance with Specifications

This is to certify that to the best of the undersigned's knowledge and belief, the data in this application is responsive and is true and correct. The undersigned understands that a non-responsive application, as defined by South Plains Community Action Association, Inc., may not be reviewed and considered by the governing body of the vendor.

Please indicate which best represents your business. Check

Is Business a HUB vendor?
(Historically Under-Utilized Business)

(Signature) (Date)

Is Business a DBE Vendor
(Disadvantaged Business Enterprise)

(Type Name and Title)

Is Business a Minority Owned Business?

(Type name and Title of person authorized to negotiate a contract if different from person listed above)

Business is part of a larger company.
(Please Specify)

(Organization)

(Address)

Is Business an SBE Vendor?
(Small Business Enterprise)

(City) (State) (Zip)

Other
(Please Specify)

(Telephone)

Program Narrative Requirements

The Proposal Narrative will describe how the potential vendor proposes to meet the specification criteria listed on (pg.8). In addition to providing a proposal narrative, please briefly answer the following 2 questions (separate from narrative). Narrative should be in a proposal format, not smaller than 12 font type.

1. Indicate the number of years of experience operating such services in a stable, sound manner.

2. Describe your organization's method and capacity to assure quality in services requested through this RFP.

Proposed Price/Cost

The bidder hereby proposes to furnish vinyl wrap, design, and installation for approximately 40 vehicles specified by this RFP as follows: At a minimum, provide a pricing quote in format for the following items:

1. Cost per hour for design services.
2. Cost per vehicle wrap by model.
3. Bulk pricing options, if applicable.
4. Specify your cost structure for the removal of existing decals, including whether pricing is based on an hourly rate, vehicle type, wrap size, or other relevant factors.
5. Estimated cost for additional services, including but not limited to surface preparation fees, custom design work, premium vinyl options, on-site installation fees, wrap repairs and maintenance, warranty extensions, and removal of vehicle accessories.

Assurances

We understand and agree that this proposal is not a contract and does not obligate South Plains Community Action Association, Inc. to pay for costs incurred in the preparation of this proposal or costs incurred prior to the execution of a written contract or prior to the receipt of funds designated for this program from the funding agency.

We understand and agree that the contract provisions may vary from the provisions set forth in this request, when deemed necessary by South Plains Community Action Association, Inc.; however, we agree to abide by the contract provisions contained in the proposed contract.

We understand and agree that South Plains Community Action Association, Inc., may utilize information provided outside of this request in evaluating this proposal.

We understand and agree that we may be subject to an on-site review and must be able and willing to provide documentation of information in the proposal at the request of South Plains Community Action Association, Inc., prior to the execution of a contract.

We understand and agree that South Plains Community Action Association, Inc., has the right to reject all proposals and negotiate outside of the terms of this proposal.

We understand and agree that South Plains Community Action Association, Inc., is not required to select the lowest cost proposal.

We understand and agree to abide by all federal, state, and local laws, policies and regulations governing these and those additional rules which may be promulgated, or as amended, subsequent to the execution of a contract.

We understand and agree that we may be subject to a monitoring review or audit by the U.S. Department of Labor, Texas Workforce Commission, Office of Inspector General, and/or South Plains Community Action Association, Inc. We also understand that we may be required to provide a copy of the most recent audit as part of the contracting process.

We understand and agree to submit this proposal in a good faith effort to provide services to the benefit of economically disadvantaged individuals eligible for services under this proposal.

Signature: _____

Date: _____

Printed Name: _____

Title: _____

Certifications Regarding Lobbying, Debarment, Suspension and Other Responsibility Matters

Applicants should refer to the regulations cited below to determine the certification to which they are required to attest. Applicants should also review instructions for certification included in the regulations before completing this form. Signature of this form provides for compliance with certification requirements under 34 CFR Part 85, "Government-wide Debarment and Suspension (Non-procurement and Government-wide Requirements for Drug-Free Workplace (Grants)." The certifications shall be treated as a material representation of fact upon which reliance will be placed when South Plains Community Action Association, Inc. determines to award covered transaction, grant, or cooperative agreement.

1. LOBBYING

As required by Section 1352, Title 31 of the U.S. Code, and implemented at 34 CFR Part 82, for persons entering into a grant or cooperative agreement over \$100,000, as defined at 34 CFR Part 82, Section 82.105 and 82.110, the applicant certifies that:

- (a) No federal appropriated funds have been paid or will be paid, by or on behalf of the undersigned, to any person for influencing or attempting to influence an officer or employee of any agency, a member of Congress, an officer or employee of Congress, or an employee of a Member of Congress in connection with the making of any Federal grant, the entering into of any cooperative agreement, and the extension, continuation, renewal, amendment, or modification of any Federal grant or cooperative agreement;
- (b) If any funds other than Federal appropriated funds have been paid or will be paid to any person for influencing or attempting to influence an officer or employee of any agency, a Member of Congress, an officer or employee of Congress, or an employee of a Member of Congress in connection with this Federal grant or cooperative agreement, the undersigned shall complete and submit Standard Form - LLL, "Disclosure Form to Report Lobbying," in accordance with its instructions;
- (c) The undersigned shall require that the language of this certification be included in the award documents for all subawards at all tiers (including subgrants, contracts under grants and cooperative agreements, and subcontracts) and that all subrecipients shall certify and disclose accordingly.

2. DEBARMENT, SUSPENSION, AND OTHER RESPONSIBILITY MATTERS

As required by Executive Order 12549, Debarment and Suspension, and implemented at 34 CFR Part 85, for WFCP active participants in primary covered transactions, as defined at 34 CFR Part 85, Sections 85.105 and 85.110, the applicant certifies that it and its principals:

- (a) Are not presently debarred, suspended, proposed for debarment, declared ineligible, or voluntarily excluded from covered transactions by any Federal department or agency.
- (b) Have not within a three-year period preceding this application been convicted of or had a civil judgment rendered against them for commission of fraud or a criminal offense in connection with obtaining, attempting to obtain, or performing a public (Federal, State, or local) transaction or contract under a public transaction; violation of Federal or State antitrust statutes or commission of embezzlement, theft, forgery, bribery, falsification or destruction of records, making false statements, or receiving stolen property;
- (c) Are not presently indicted for or otherwise criminally or civilly charged by a governmental entity (Federal, State, or local) with commission of any of the offenses enumerated in paragraph (1) (b) of certification; and
- (d) Have not within a three-year period preceding this application had one or more public transactions (Federal, State, or local) terminated for cause or default; and
- (e) Where the applicant is unable to certify any of the statements of this

certification, he or she shall attach an explanation to this application.

3. DRUG-FREE WORKPLACE (GRANTEES OTHER THAN INDIVIDUALS)

As required by the Drug-Free Workplace Act of 1988, and implemented at 34 CFR Part 85, Subpart F, for grantees, as defined at 34 CFR Part 85, Sections 85.605 and 85.610, the applicant certifies that it will or will continue to provide a drug-free workplace by:

- (a) Publishing a statement notifying employees that the unlawful manufacture, distribution, dispensing, possession, or use of a controlled substance is prohibited in the grantee's workplace and specifying the actions that will be taken against employees for violation of such prohibition.
- (b) Establishing an on-going drug-free awareness program to inform employees about –

- (1) The dangers of drug abuse in the workplace.
- (2) The grantee's policy of maintaining a drug-free workplace.
- (3) Any available drug counseling, rehabilitation, and employee assistance programs; and
- (4) The penalties that may be imposed upon employees for drug abuse violations occurring in the workplace.

Making it a requirement that each employee be engaged in the performance of the grant be given a copy of the statement required by paragraph (a).

- (d) Notifying the employee in the statement required by paragraph (a) that, as a condition of employment under the grant, the employee will –

- (1) Abide by the terms of the statement; and
- (2) Notify the employer in writing of his or her conviction for a violation of a criminal drug statute occurring in the workplace no later than five calendar days after such a conviction.

- (e) Notifying the agency, in writing, within 10 calendar days after receiving notice under subparagraph (d)(2) from an employee or otherwise receiving actual notice of such conviction. Employers of convicted employees must provide notice, including position title to:

Bill Powell
South Plains Community Action Association, Inc.
411 Austin St. -- P.O. Box 610
Levelland, Texas 79336

Notice shall include the identification number(s) of each affected grant.

- (f) Taking one of the following actions, within 30 calendar days of receiving notice under subparagraph (d)(2), with respect to any employee who is so convicted –

- (1) Taking appropriate personnel action against such an employee, up to and including termination, consistent with the requirements of the Rehabilitation Act of 1973, as amended; or
- (2) Requiring such employees to participate satisfactorily in a drug abuse assistance or rehabilitation program approved for such purposes by a Federal, State, or local health, law enforcement, or other appropriate agency.

- (g) Making a good faith effort to continue to maintain a drug-free workplace

through implementation of paragraphs (a), (b), (c), (d), (e), and (f).

(g) The grantee may insert in the space provided below the site(s) for the performance of work done in connection with the specific grant:
Place of Performance (street address, city, county, state, zip code)

Check if there are workplaces on file that are not identified here.

4. DRUG-FREE WORKPLACE (GRANTEES WHO ARE INDIVIDUALS)

As required by the Drug-Free Workplace Act of 1988, and at 34 CFR Part 85, Sections 86.605 and 85.610 -

(a) As a condition of the grant, I certify that I will not engage in the unlawful manufacture, distribution, dispensing, possession, or use of a controlled substance in conducting any activity with the grant.

(b) If convicted of a criminal drug offense resulting from a violation occurring during the conduct of any grant activity, I will provide notice of such conviction, in writing, within 10 calendar days of the conviction to:

Executive Director
South Plains Community Action Association, Inc.
411 Austin St.
P.O. Box 610
Levelland, Texas 79336

5. AMERICANS WITH DISABILITIES ACT

By signing the certification below, the applicant assures that it will comply with the provisions of the Americans with Disabilities Act (ADA) of 1990, and the Rules and regulations promulgated thereunder, requiring employers to not discriminate against a qualified job applicant or employee because of a disability and ensuring that all existing and new facilities provide easy access for people with disabilities.

As the duly authorized representative of the applicant, I hereby certify that the applicant will comply with the above certifications.

NAME OF APPLICANT:

**CONTRACT NUMBER AND/OR PROJECT
NAME:**

**PRINTED NAME AND TITLE OR
AUTHORIZED REPRESENTATIVE:**

SIGNATURE:

DATE:

Evaluation Table and Proposal Rating Summary

For Office Use Only

Name of Proposal: _____

Evaluation Criteria	Possible Points	Points Given
Quality of materials and installation plan	25	
Compliance with RFP Requirements	20	
Experience and qualifications	20	
Cost Proposal	20	
Project timeline and execution plan.	10	
HUB/DBE/SBE Participation	5	
Total	100	

Proposal Recommendations:

Justification:

Addendum A

1. **Customizability:** Proposals should demonstrate the ability to create highly customizable wraps, incorporating brand-specific colors, logos, imagery, and contact details that enhance SPARTAN's branding and public visibility.
2. **Types of Wraps:** Vendors must specify the available options, including window coverings, spot graphics, partial vehicle wraps, and full vehicle wraps. Each type should be tailored to different branding needs, as applicable.
3. **Materials and Quality:** Proposals must specify the use of high-quality, durable vinyl materials that are resistant to UV rays, dirt, and debris, ensuring longevity and minimal maintenance. Specify useful life and warranty of vinyl proposed. SPARTAN keeps vehicles between 5-7 years.
4. **Installation Process:** Vendors must outline the installation process, including vehicle preparation (cleaning and surface treatment) and the steps taken to ensure a seamless and professional application.
5. **Project Management:** A dedicated project manager should be assigned to oversee the coordination and execution of the fleet wrap project, particularly for large-scale installations.
6. **Cost and Budget:** Vendors should provide a detailed cost breakdown, accounting for wrap size, vehicle model, materials used, and additional fees such as wrap removal or maintenance, as applicable.
7. **Maintenance and Repair:** Proposals must describe the ease of maintaining and repairing wraps, including the process of replacing damaged sections without affecting the overall design.
8. **Consultation and Design Support:** Vendors should outline their design consultation services, ensuring collaboration with SPARTAN's team to align graphics with branding and advertising objectives. This includes refining and developing final designs based on SPARTAN's rough draft graphics provided on pg.17.
9. **Location and Availability:** Vendors must confirm their ability to perform installations at SPARTAN's designated locations or provide alternative installation sites within reasonable proximity.
10. **Customer Service:** Vendors should demonstrate a commitment to excellent customer service, ensuring clear communication and support throughout the design, production, and installation phases.
11. **Vehicle Models & Dimensions:** Vendors must ensure all designs and installations conform to the specifications provided on pg.21.

Rough Draft Graphics

Rough Draft Graphics follow this page.

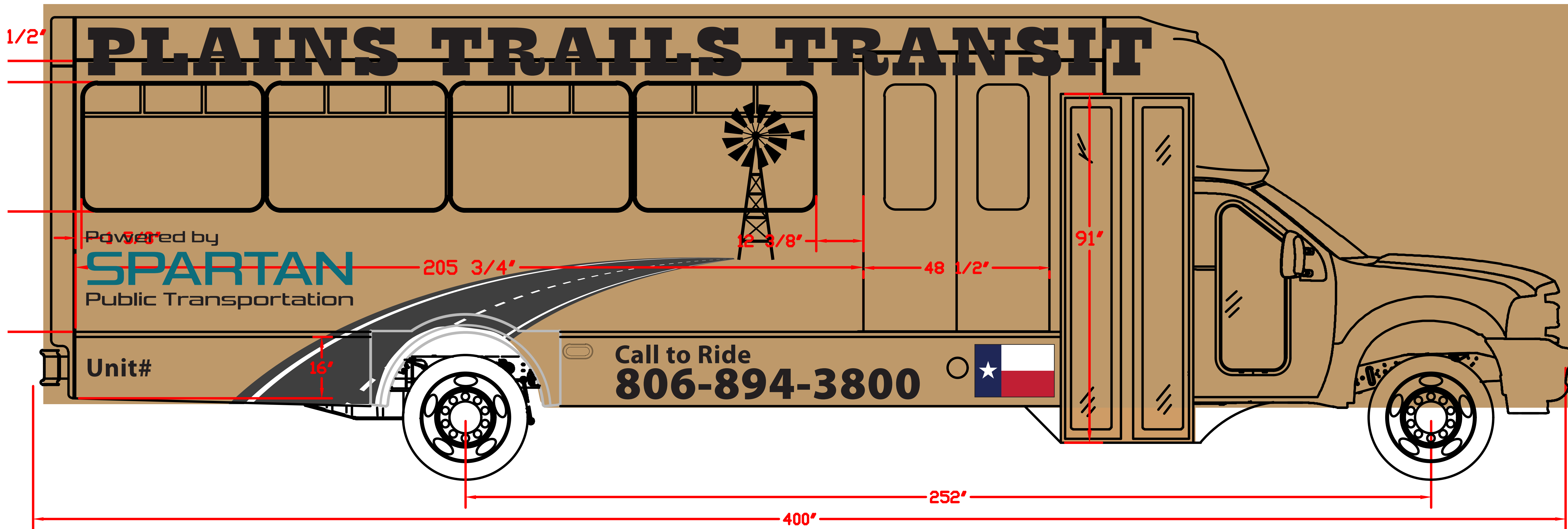

Date:	W/C Lift	FL
Apr. 1, 2010	Front	
GLAVALL		

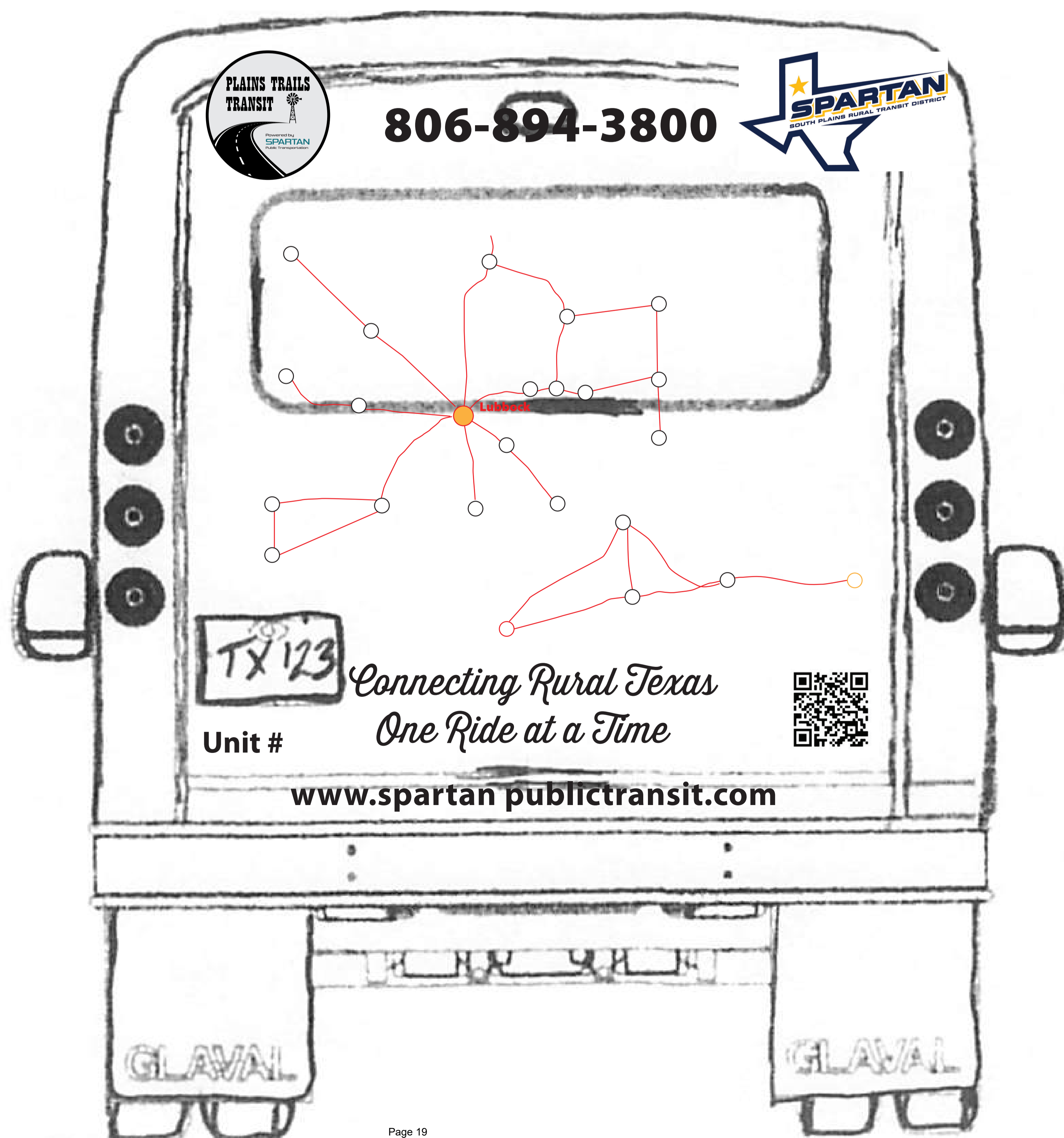
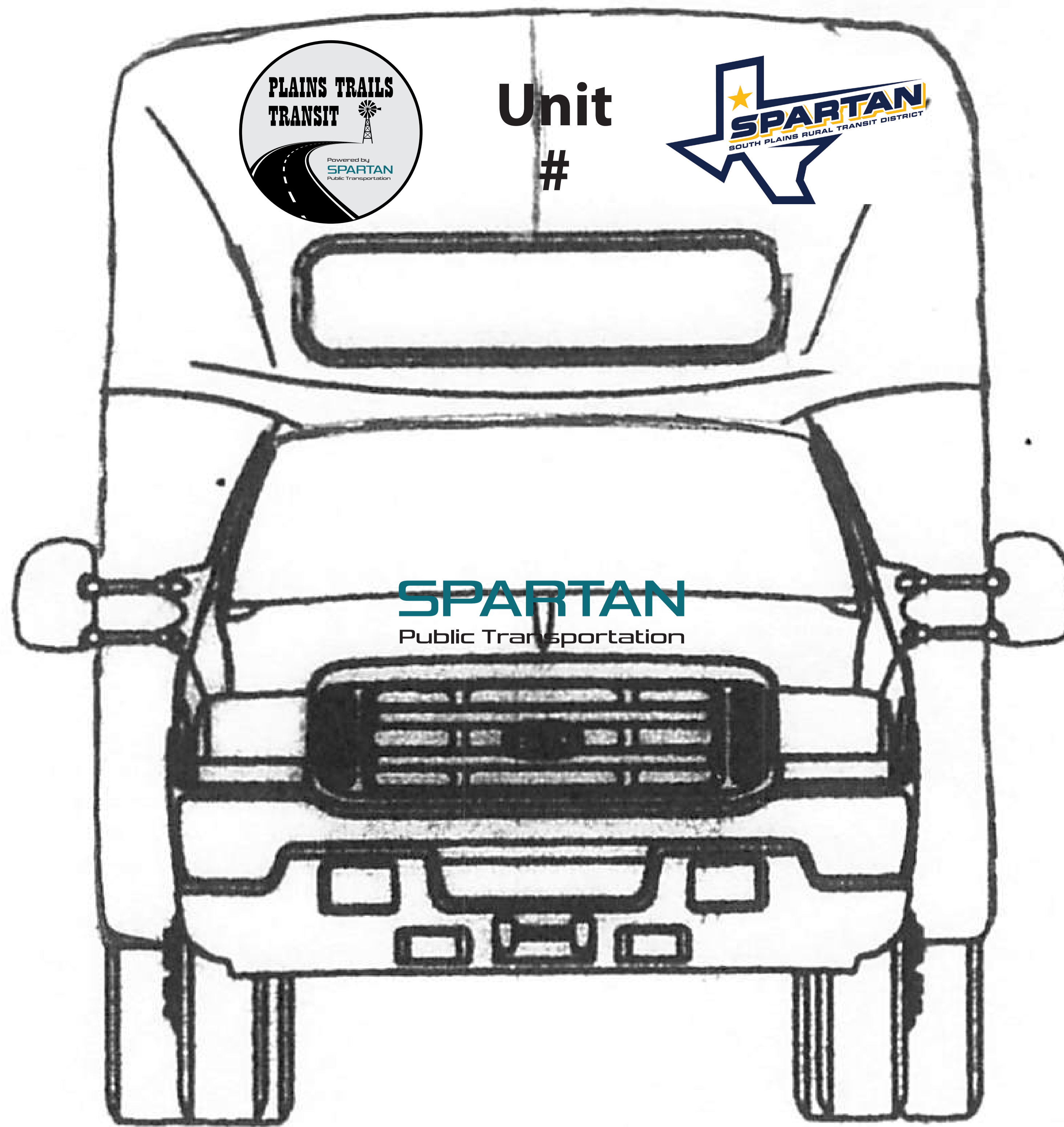

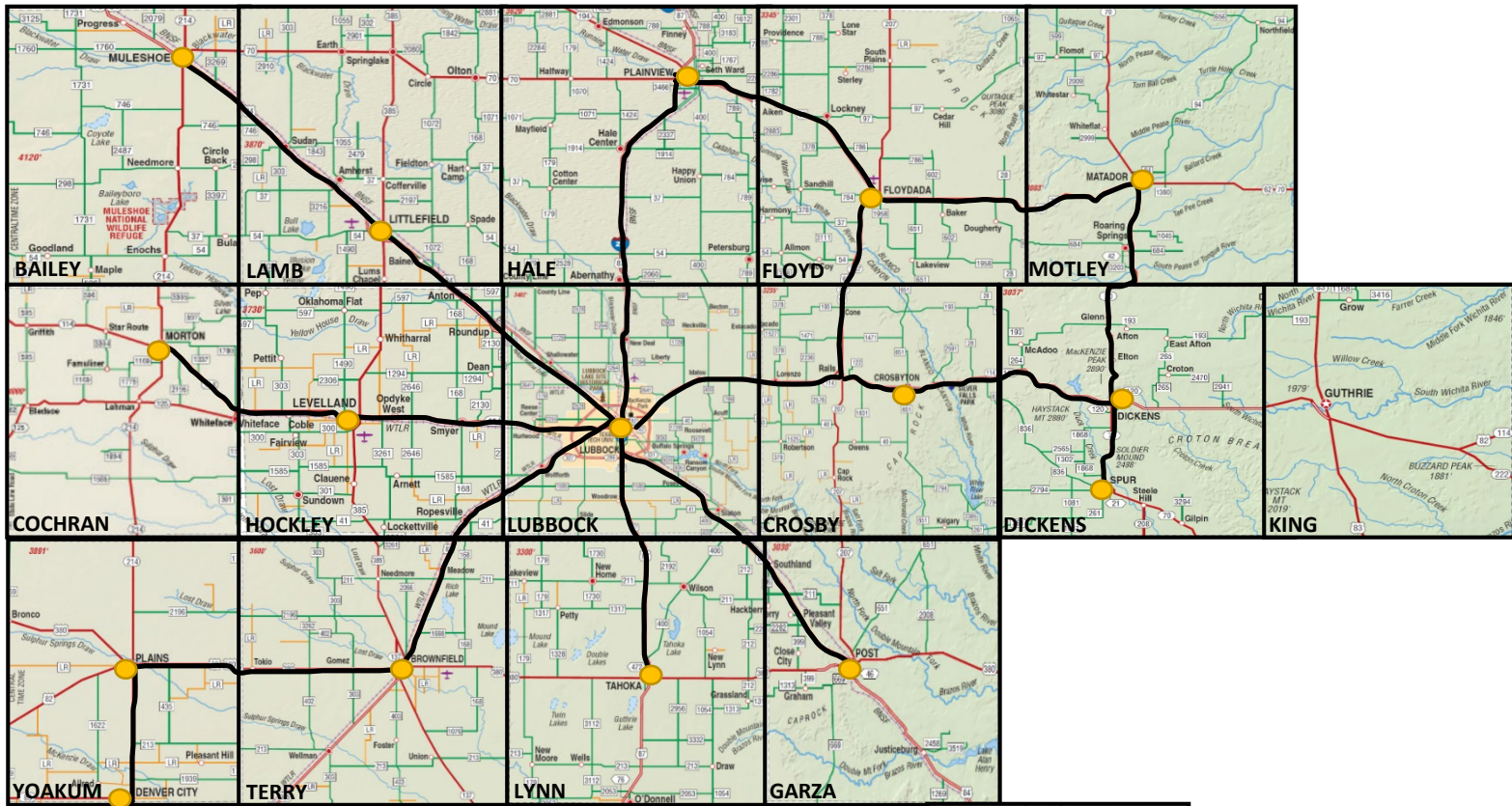

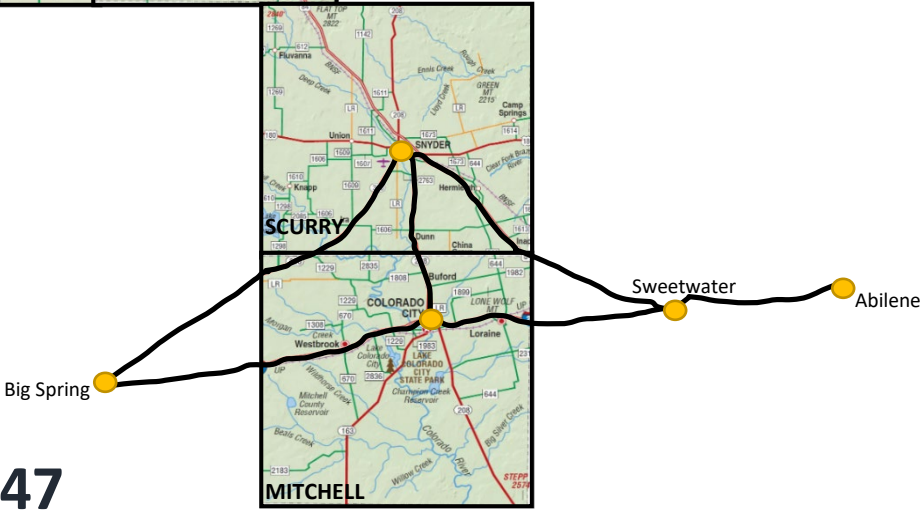

1-800-462-8747

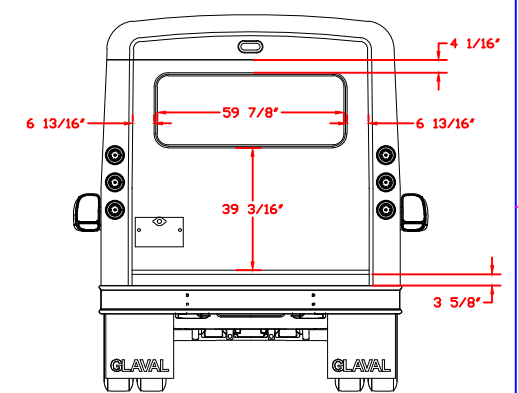
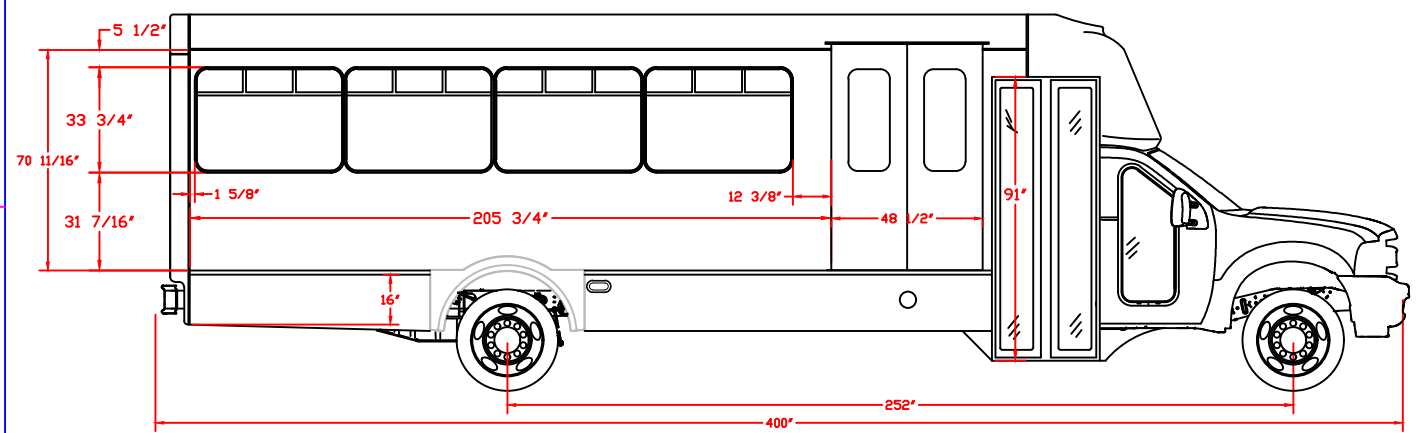
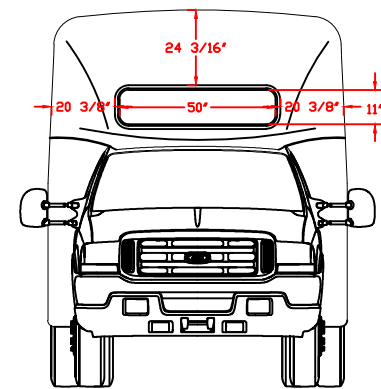
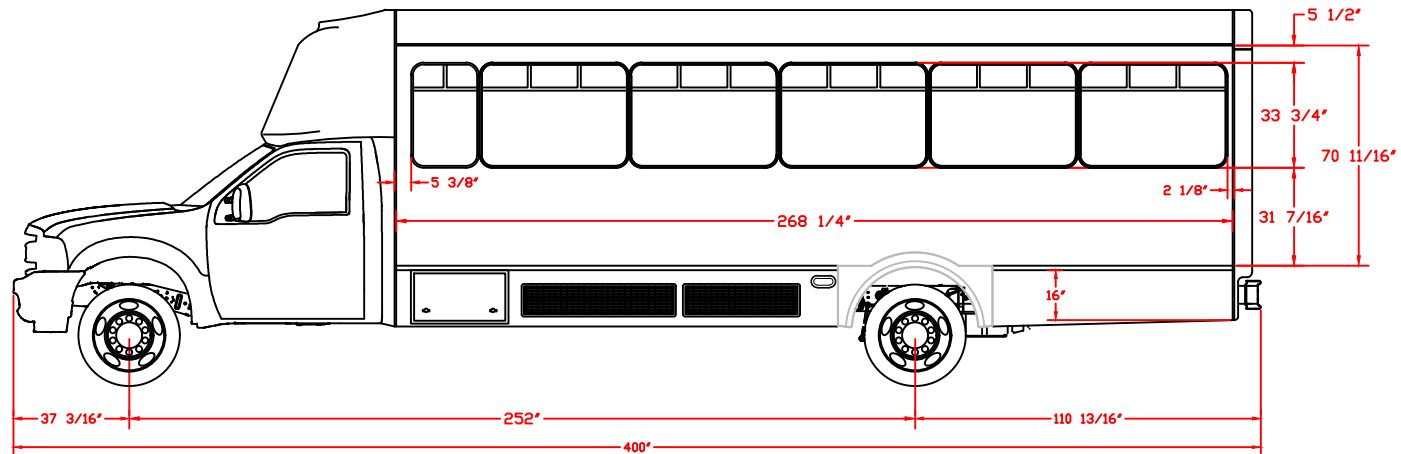

Elevation Drawings

Elevation Drawings follow this page.



Date:	W/C Lift	Floor	Ent Door	Model:	Wheel Base	Drawn By:
Apr. 1, 2010	Front		30"	33' Entourage	252"	D Buell
 Buses for the new millenium				ELEVATION		
				Part No:	Revision:	

NOTE: ADD 2" FOR ROMED REAR BUMPER

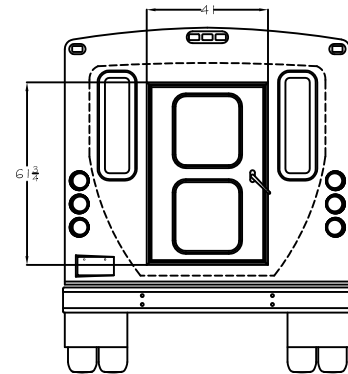
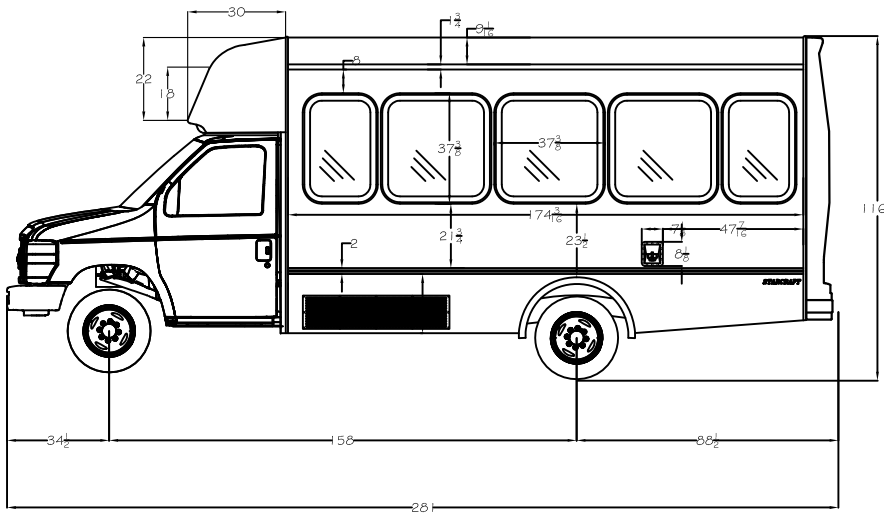
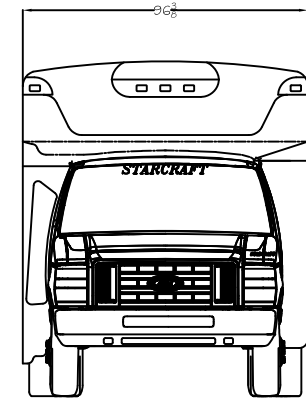
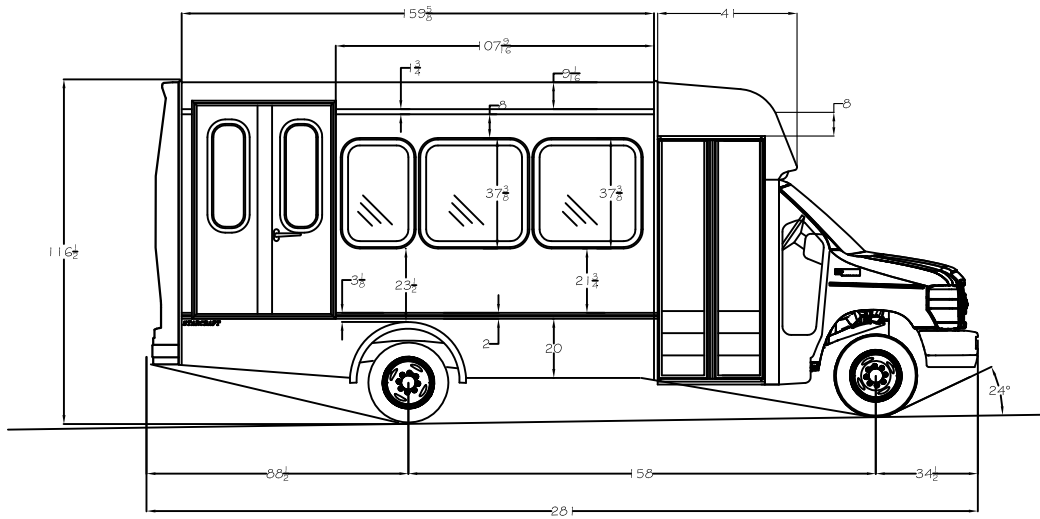

ALLSTAR
FORD

THIS DRAWING AND THE INFORMATION THEREON ARE THE EXCLUSIVE PROPERTY OF THE STARCRAFT CORPORATION. IT SHALL NOT BE COPIED OR DUPLICATED IN ANY MANNER, NOR SHALL IT BE SUBMITTED TO OUTSIDE PARTIES FOR EXAMINATION WITHOUT OUR WRITTEN CONCENT. IT IS LOANED FOR USE WITH REFERENCE TO WORK UNDER CONTRACT WITH, OR PROPOSALS SUBMITTED TO THE STARCRAFT CORPORATION.

REV. LET.	DESCRIPTION OF CHANGE	DATE	ECN No.



STARCRAFT BUS

TOLERANCE UNLESS OTHERWISE SPECIFIED	DATE: 06/17/15	TITLE
WOOD ± 1/8" OTHER ± 1/16"	DFTSN: JPC	158' WB 22' ALLSTAR ELEVATIONS
± 1" ± 1/2"	CHKR:	SCALE
APRVD:	DWG. No. 158 WB 22FT 2011	DWG. No. 158 WB 22FT 2011
	DISK No.	SHEET 1 OF 2

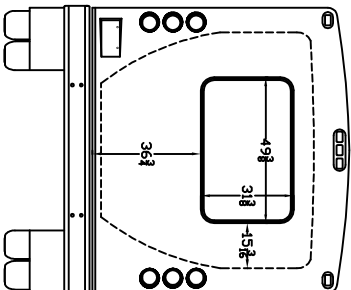
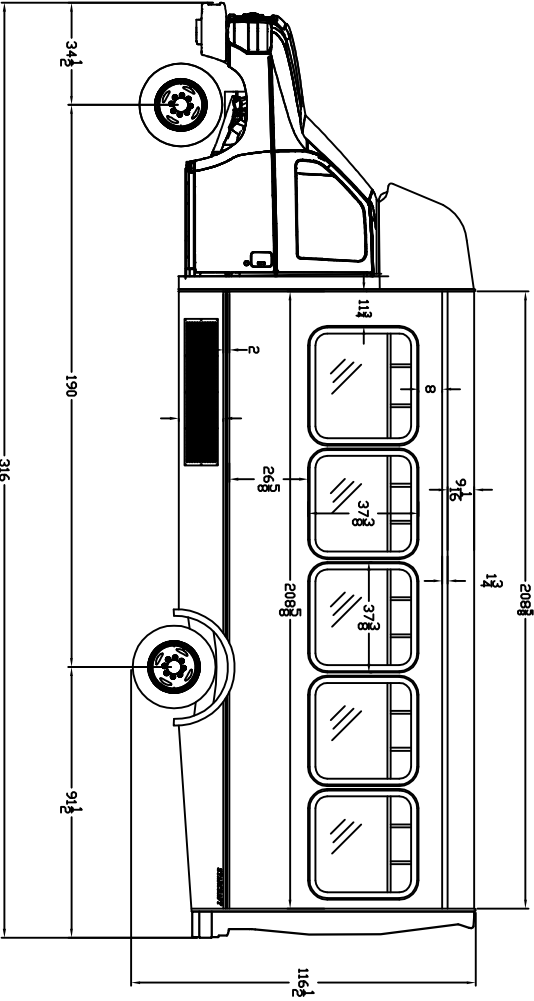
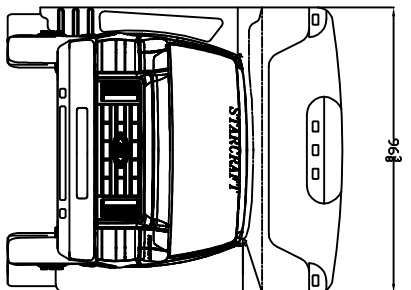
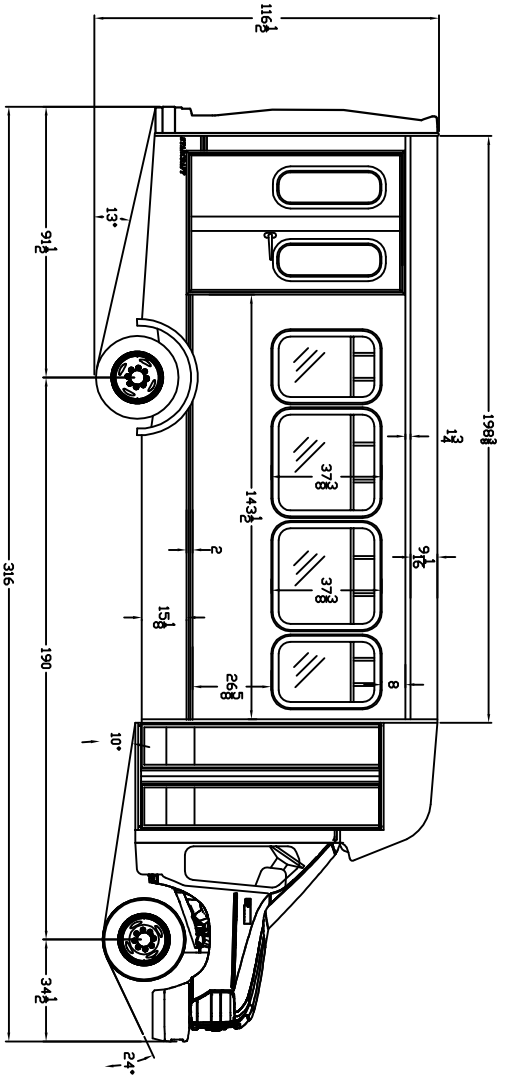

2011 ALLSTAR
 FORD

E-450 14,500 GVWR

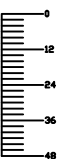

THIS DRAWING AND THE INFORMATION THEREON ARE THE EXCLUSIVE PROPERTY OF THE STARCRRAFT CORPORATION. IT SHALL NOT BE COPIED OR DUPLICATED IN ANY MANNER, NOR SHALL IT BE SUBMITTED TO OUTSIDE PARTIES FOR EXAMINATION WITHOUT OUR WRITTEN CONSENT. IT IS LOANED FOR USE WITH REFERENCE TO WORK UNDER CONTRACT WITH, OR PROPOSALS SUBMITTED TO THE STARCRRAFT CORPORATION.



STARCRRAFT BUS

REV.	DESCRIPTION OF CHANGE	BY	CHK	DATE	ECN No.	± 1"	± 1/2"	APPRVD.	DISK No.	SHEET 1	OF 1
						DATE: 10/17/11					
						TITLE: 190' W/B 26' ALLSTAR ELEVATIONS					
						SCALE: DVG No. 190 W/B 26FT 2011					
						TOLERANCE UNLESS OTHERWISE SPECIFIED: WOOD ± 1/8" OTHER ± 1/16"					
						DATE: 10/17/11					
						DFTSN: MDK					
						CHKR:					
						APPRVD:					

NOTE: ADD 2" FOR ROMEO REAR BUMPER

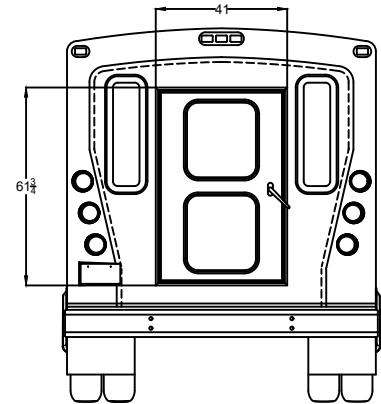
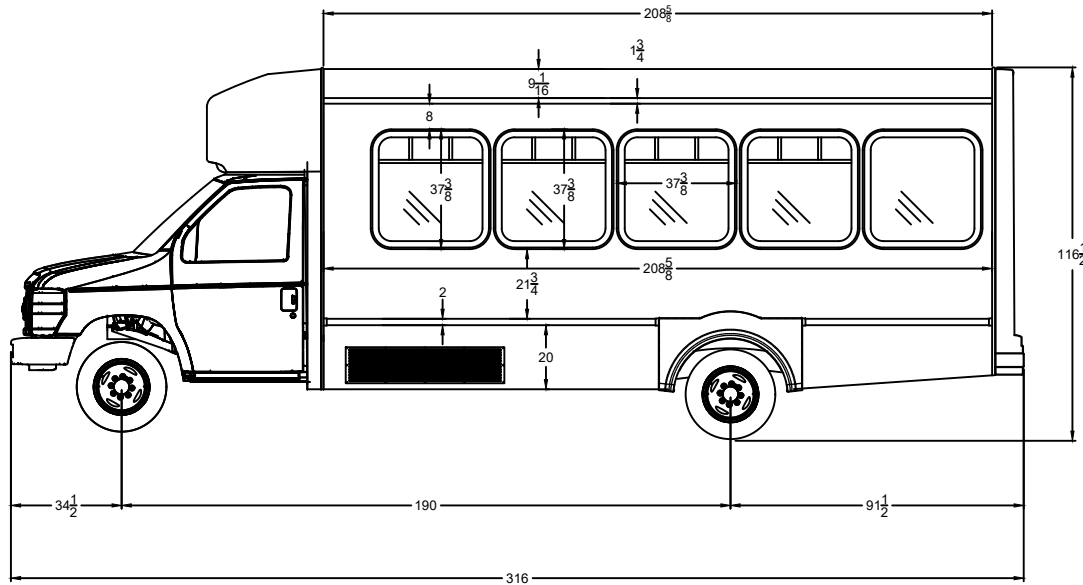
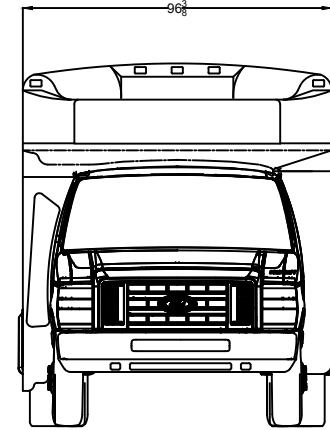
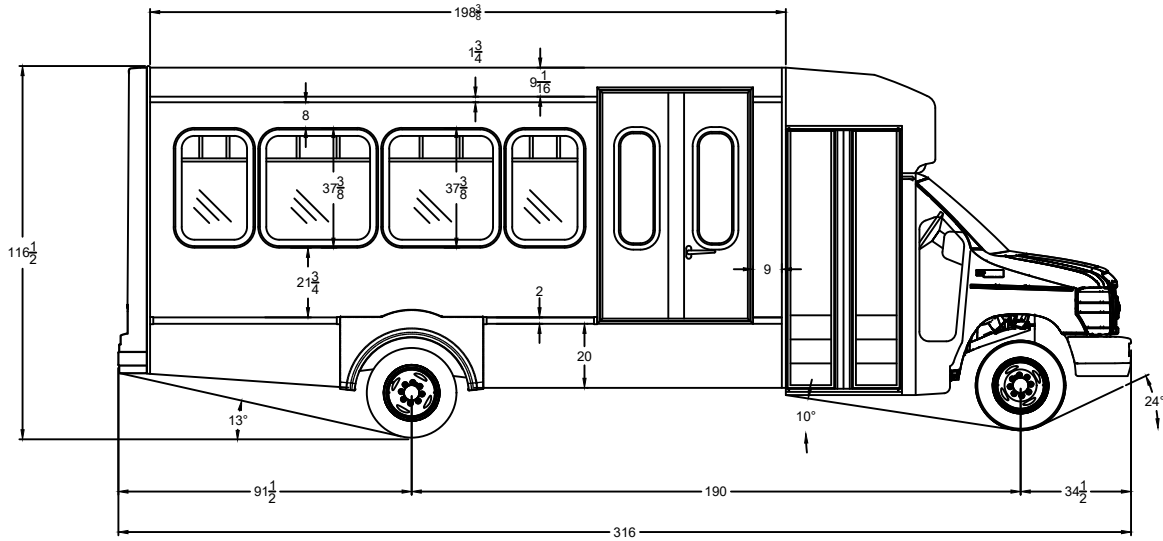

2019 UNIVERSAL
 Raised Floor
 Front Lift

THIS DRAWING AND THE INFORMATION THEREON ARE THE EXCLUSIVE PROPERTY OF FOREST RIVER BUS, A DIVISION OF FOREST RIVER. IT SHALL NOT BE COPIED OR DUPLICATED IN ANY MANNER, NOR SHALL IT BE SUBMITTED TO OUTSIDE PARTIES FOR EXAMINATION WITHOUT OUR WRITTEN CONSENT. IT IS LOANED FOR USE WITH REFERENCE TO WORK UNDER CONTRACT WITH, OR PROPOSALS SUBMITTED TO FOREST RIVER BUS, A DIVISION OF FOREST RIVER.

REV. LET.	DESCRIPTION OF CHANGE	BY	CHK	DATE	ECN No.

TOLERANCE UNLESS OTHERWISE SPECIFIED

WOOD	+ 1/8"	+ 1/16"
OTHER	+ 1"	+ 1/2"

FOREST RIVER BUS

TITLE:
 158 WB 22FT UNIVERSAL

NAME: LG DATE: 02/21/25

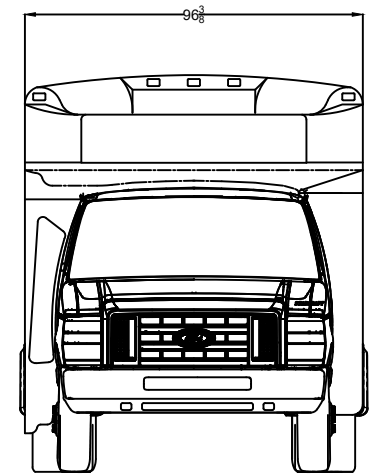
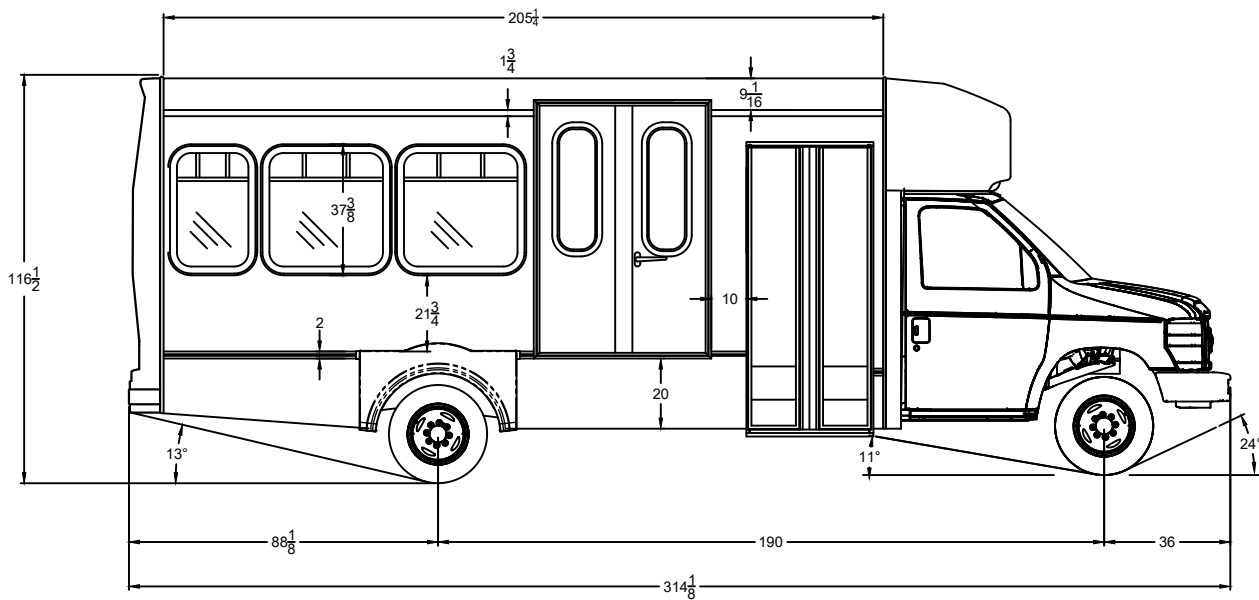

AIRPORTER FORD

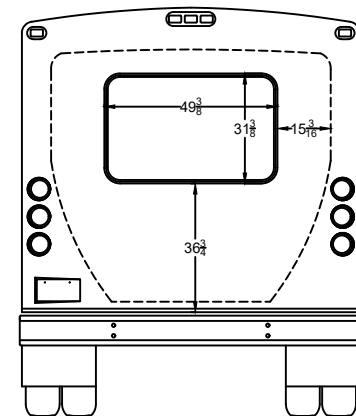
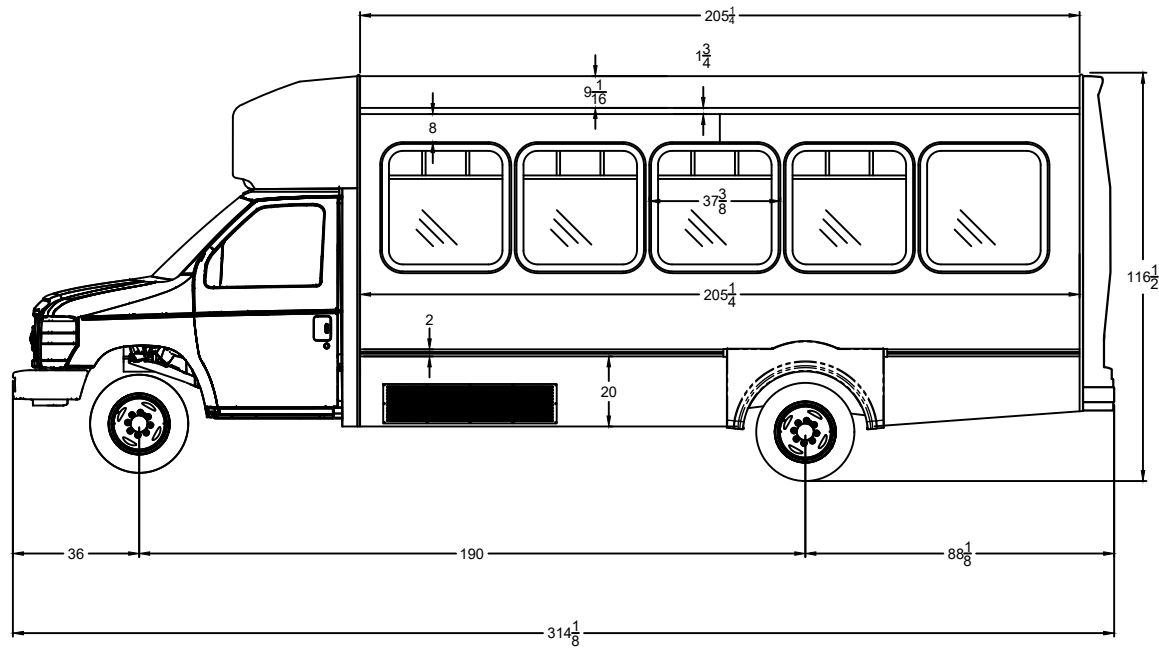

RAISED FLOOR

THIS DRAWING AND THE INFORMATION THEREON ARE THE EXCLUSIVE PROPERTY OF FOREST RIVER BUS, A DIVISION OF FOREST RIVER. IT SHALL NOT BE COPIED OR DUPLICATED IN ANY MANNER, NOR SHALL IT BE SUBMITTED TO OUTSIDE PARTIES FOR EXAMINATION WITHOUT OUR WRITTEN CONSENT. IT IS LOANED FOR USE WITH REFERENCE TO WORK UNDER CONTRACT WITH, OR PROPOSALS SUBMITTED TO FOREST RIVER BUS, A DIVISION OF FOREST RIVER.

REV. LET.	DESCRIPTION OF CHANGE	BY	CHK	DATE	ECN No.
Page 26					
DWG: 190 WB 210 Airporter					

TOLERANCE UNLESS OTHERWISE SPECIFIED			TITLE:	
WOOD	± 1/8"		± 1/16"	190" WB 26' AIRPORTER ELEVATION
OTHER	± 1"	± 1/2"	NAME:	DATE:
FOREST RIVER BUS		LG	02/21/25	

NOTE: ADD 2" FOR ROMEO REAR BUMPER

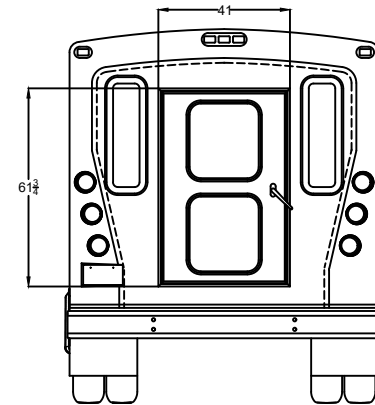
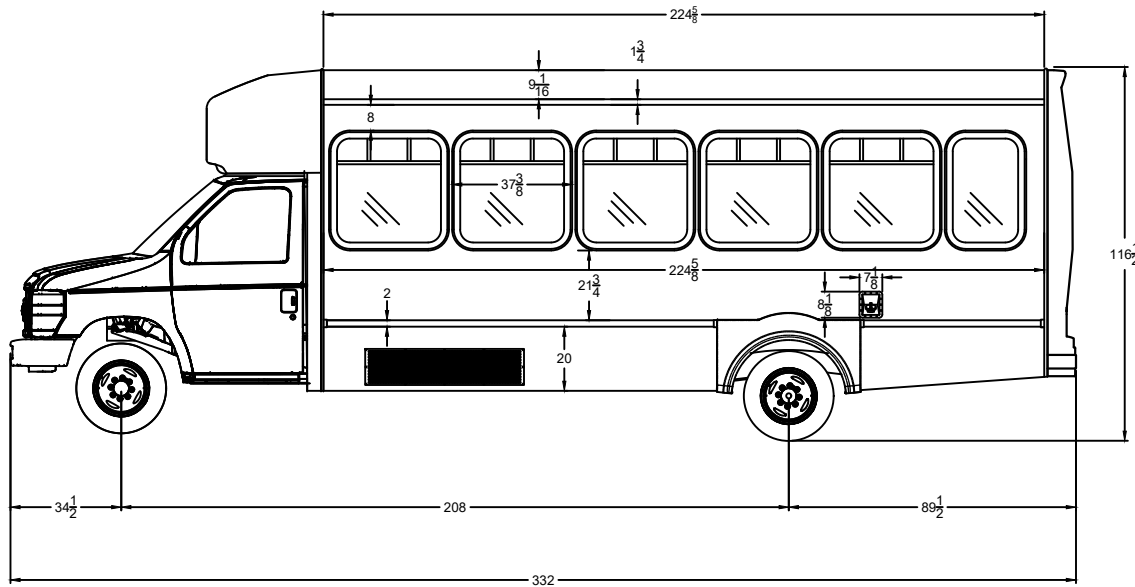
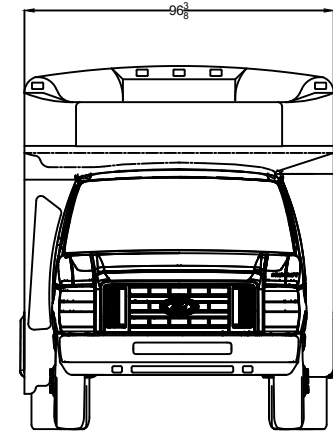
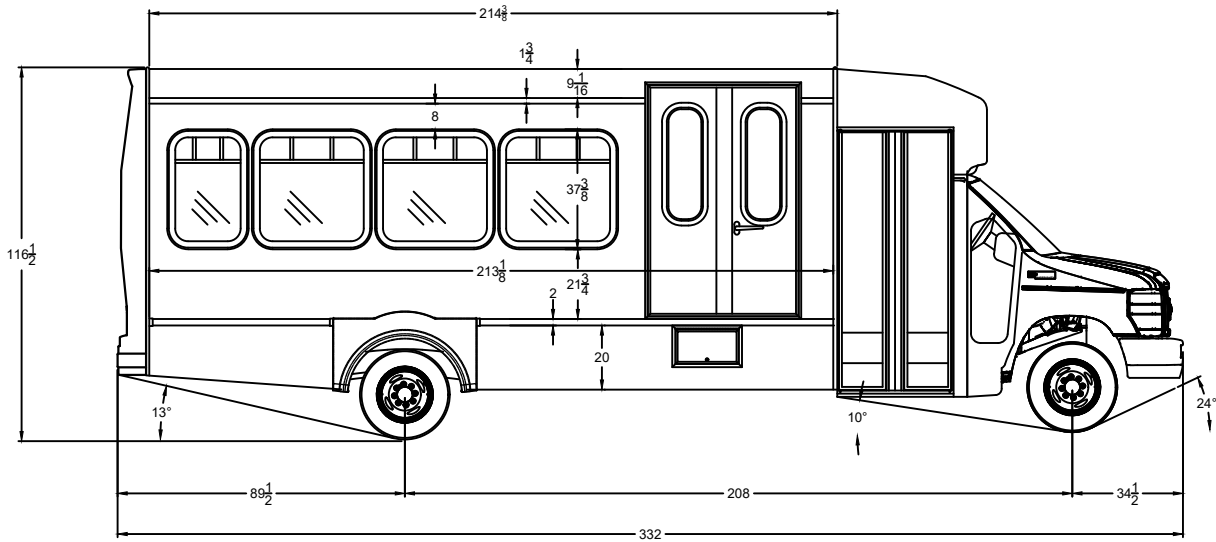

2019 UNIVERSAL
Front Lift
RAISED FLOOR

THIS DRAWING AND THE INFORMATION THEREON ARE THE EXCLUSIVE PROPERTY OF FOREST RIVER BUS, A DIVISION OF FOREST RIVER. IT SHALL NOT BE COPIED OR DUPLICATED IN ANY MANNER, NOR SHALL IT BE SUBMITTED TO OUTSIDE PARTIES FOR EXAMINATION WITHOUT OUR WRITTEN CONSENT. IT IS LOANED FOR USE WITH REFERENCE TO WORK UNDER CONTRACT WITH, OR PROPOSALS SUBMITTED TO FOREST RIVER BUS, A DIVISION OF FOREST RIVER.

REV. LET.	DESCRIPTION OF CHANGE	BY	CHK	DATE	ECN No.	TOLERANCE UNLESS OTHERWISE SPECIFIED
						WOOD ± 1/8" OTHER ± 1/16"
						WOOD ± 1" OTHER ± 1/2"



TITLE: 208" WB 27" ELEVATIONS	
NAME: LG	DATE: 02/21/25

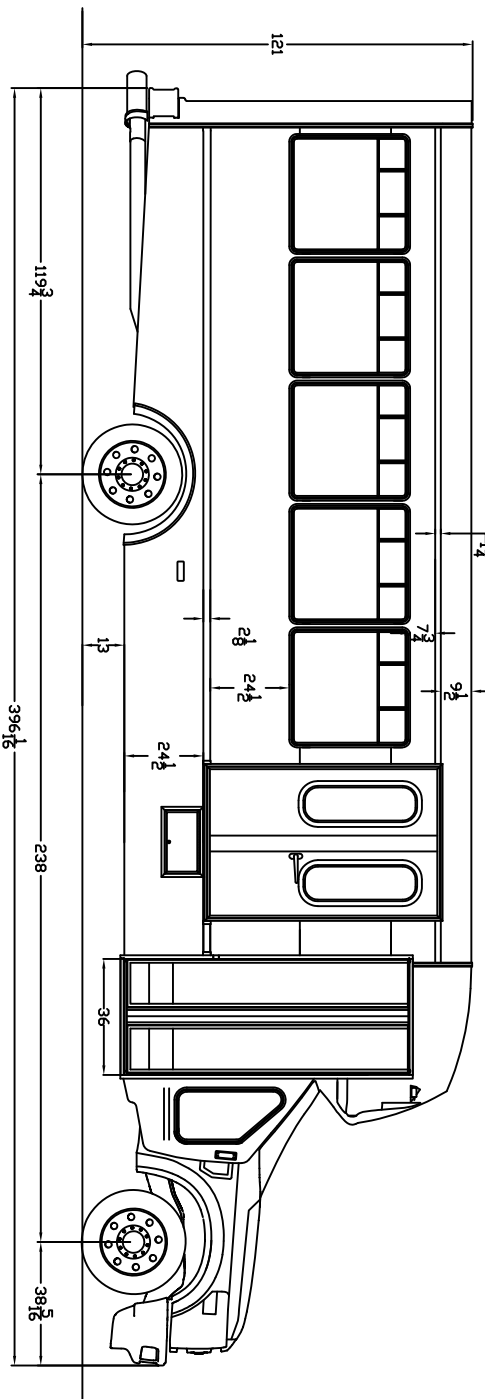
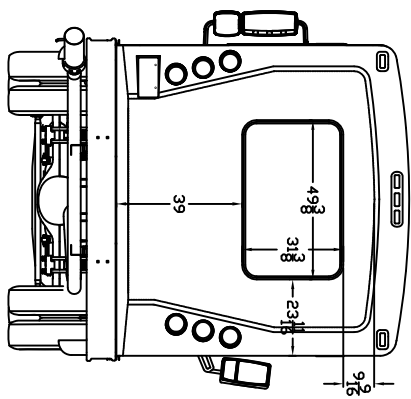
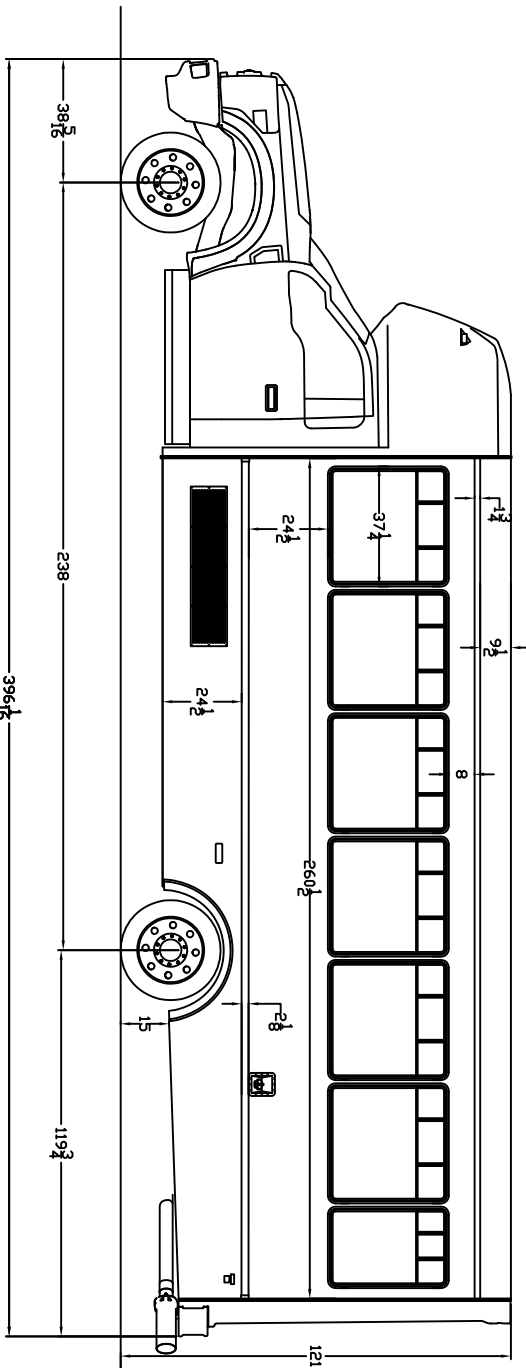
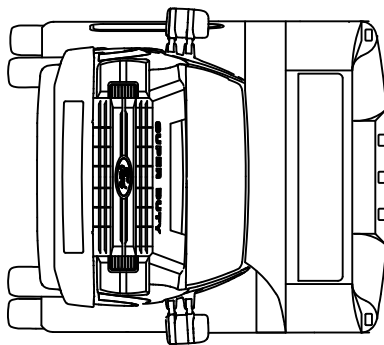

THIS DRAWING AND THE INFORMATION THEREON ARE THE EXCLUSIVE PROPERTY OF GLAVAL BUS, A DIVISION OF FOREST RIVER. IT SHALL NOT BE COPIED OR DUPLICATED IN ANY MANNER, NOR SHALL IT BE SUBMITTED TO OUTSIDE PARTIES FOR EXAMINATION WITHOUT OUR WRITTEN CONSENT. IT IS LOANED FOR USE WITH REFERENCE TO WORK UNDER CONTRACT WITH, OR PROPOSALS SUBMITTED

REV.	DESCRIPTION OF CHANGE	BY	CHK	DATE	ECN No.	TOLERANCE UNLESS OTHERWISE SPECIFIED	GLAVAL BUS
						WOOD ± 1/8"	GLAVAL BUS Buses for the new millennium TITLE: 238' MB 2019 FORD F-550 33' ENTOURAGE
						OTHER ± 1/16"	
						NAME: TAS	
						DWG. No. 238' MB 264' BDY FRONT LIFT	

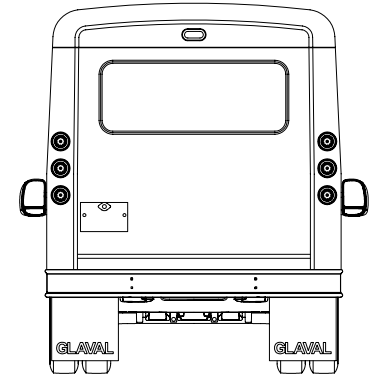
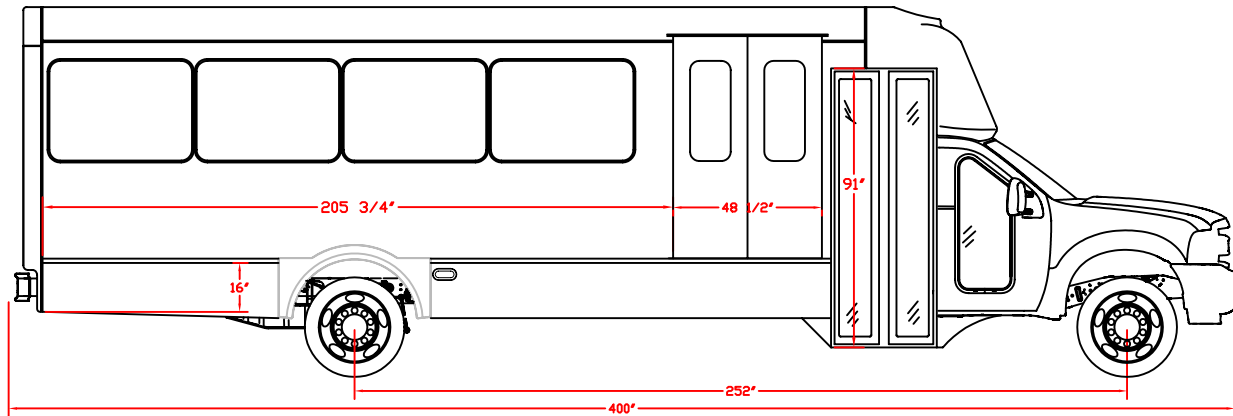
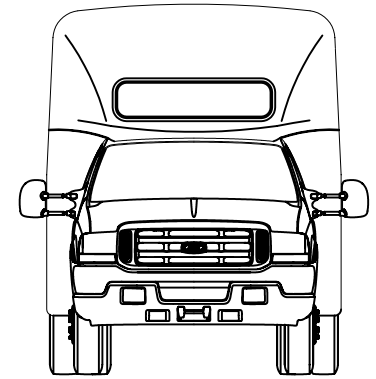
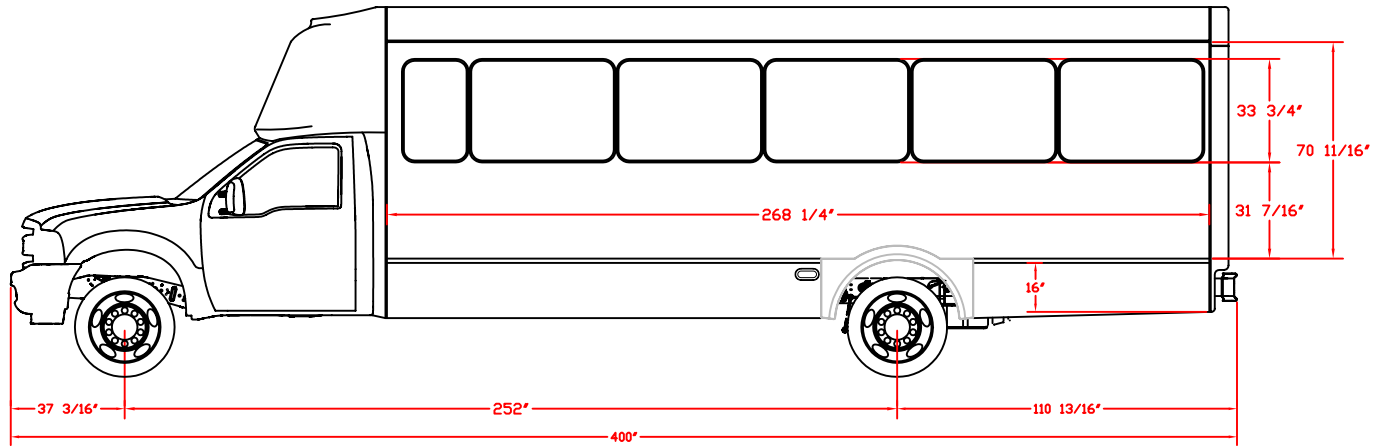

Date:	W/C Lift	Floor	Ent Door	Model:	Wheel Base	Drawn By:
Apr. 1, 2010	Front		30"	33' Entourage	252"	D Buell
				ELEVATION		
				Part No:	Revision:	

Driver Side

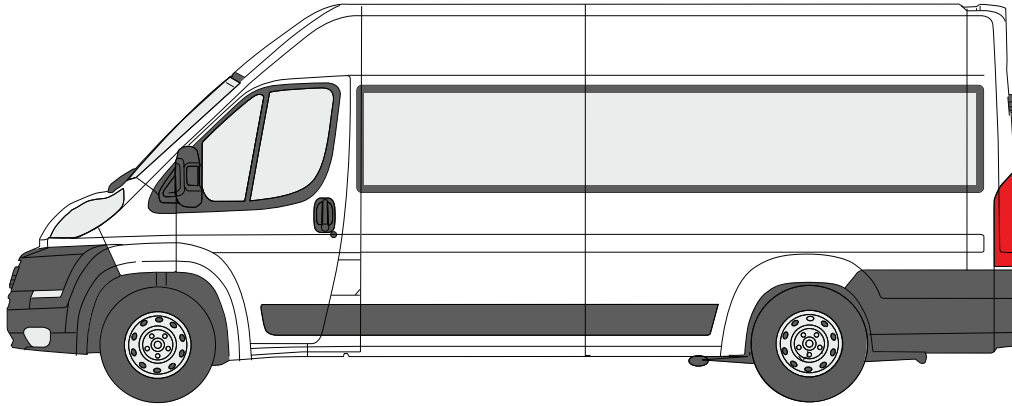

Front

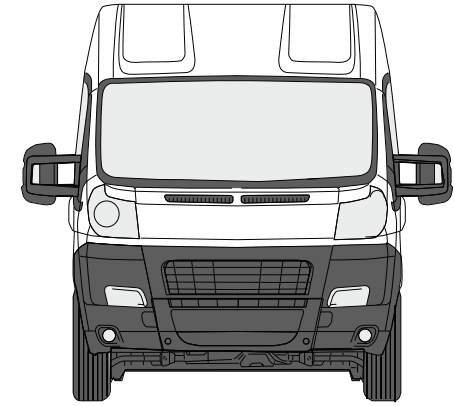

Passenger Side

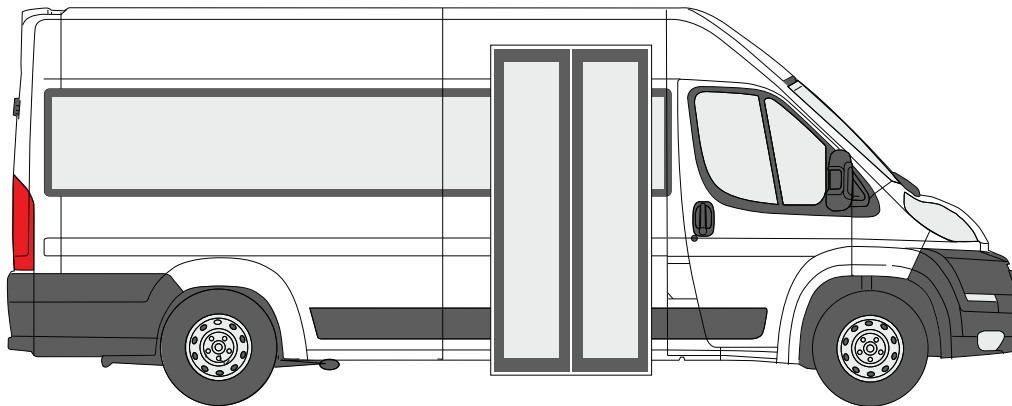

Rear

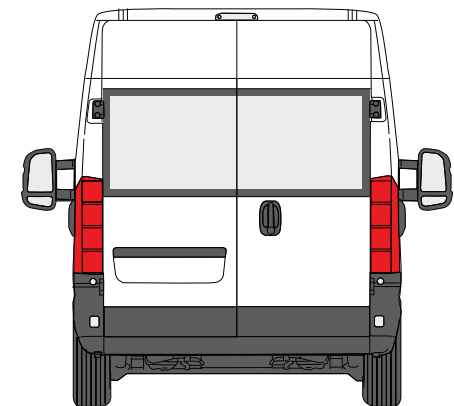

Driver Side Dimensions

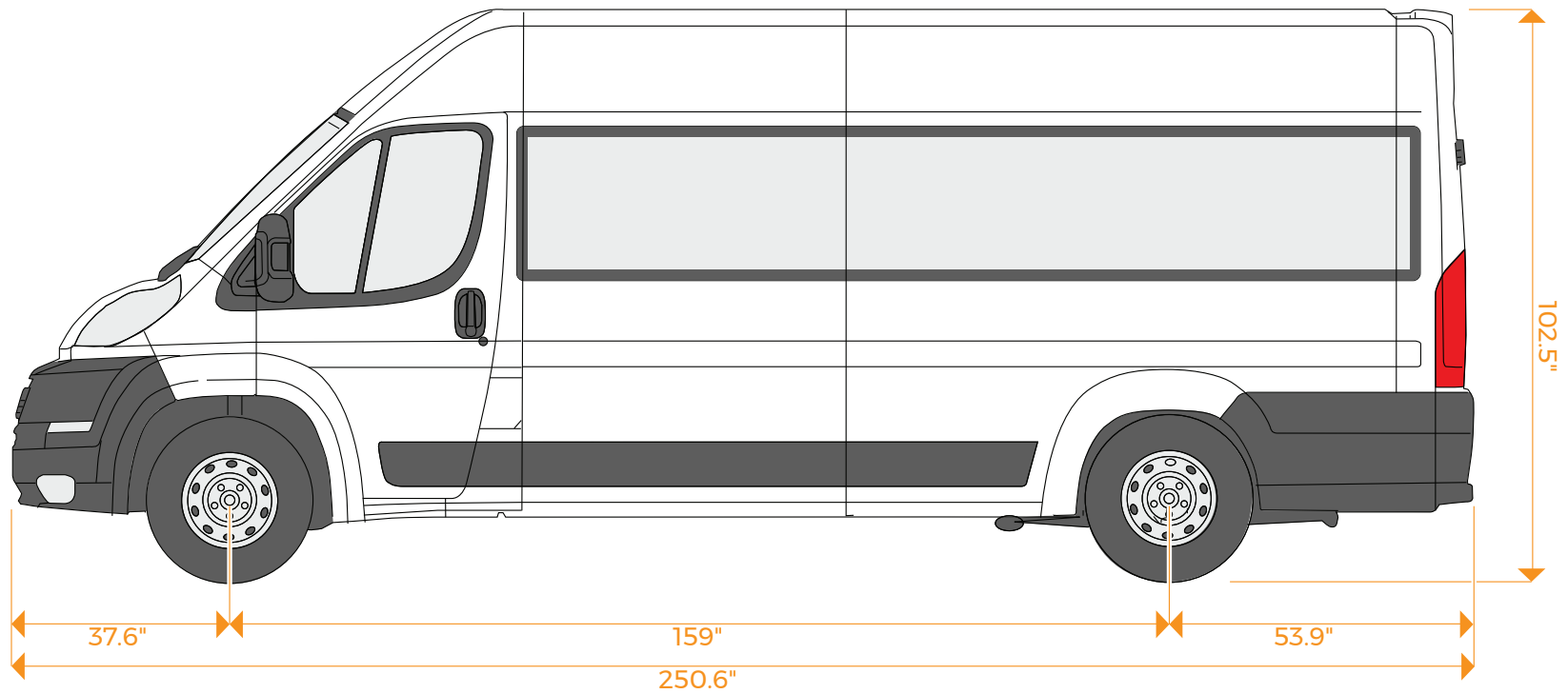

Note: Due to manufacturing tolerances both with the OEM vehicle and the conversion components, all dimensions may vary slightly from those shown.

Driver Side Dimensions

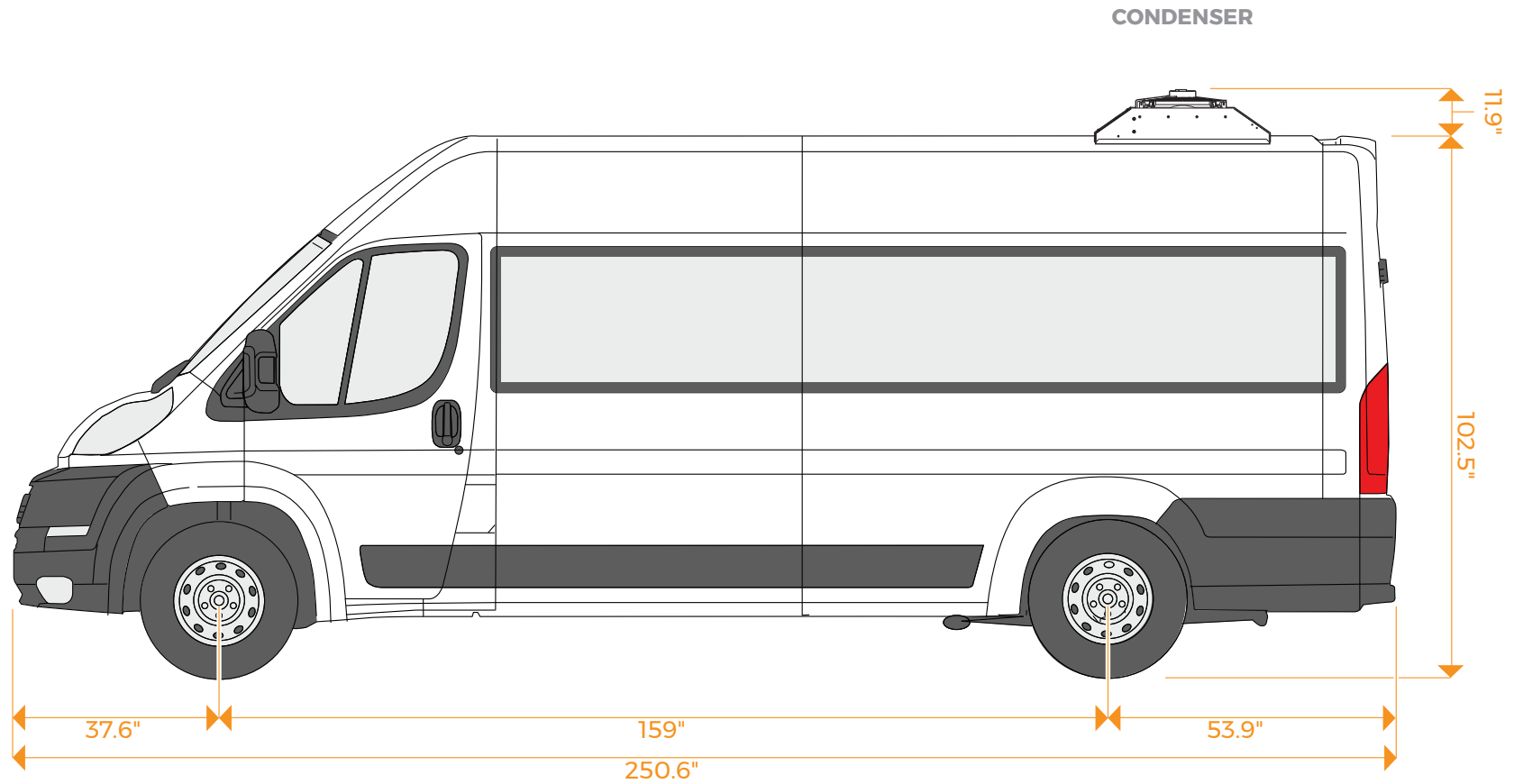

Note: Due to manufacturing tolerances both with the OEM vehicle and the conversion components, all dimensions may vary slightly from those shown.

Driver Side Dimensions

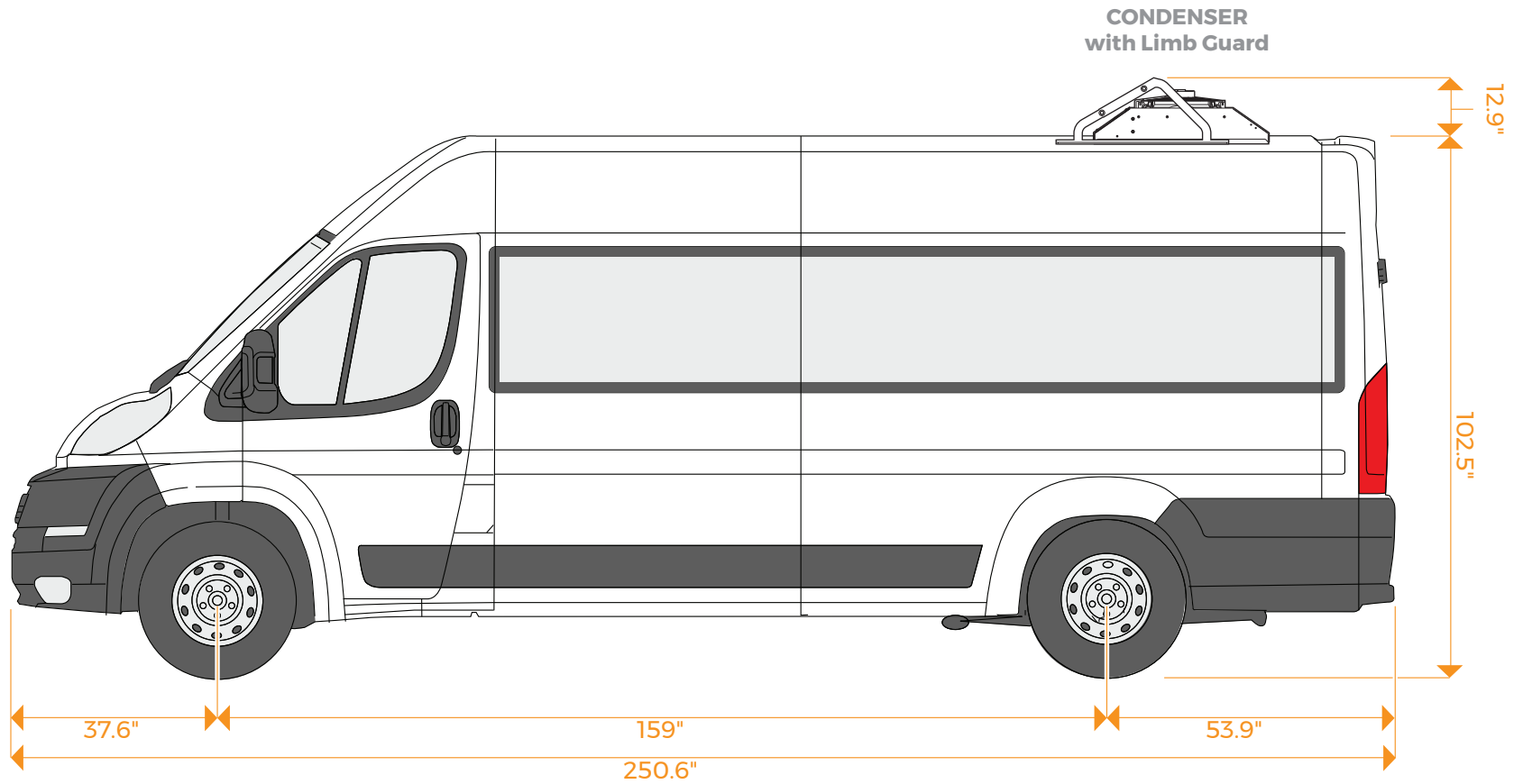

Note: Due to manufacturing tolerances both with the OEM vehicle and the conversion components, all dimensions may vary slightly from those shown.

Passenger Side Dimensions

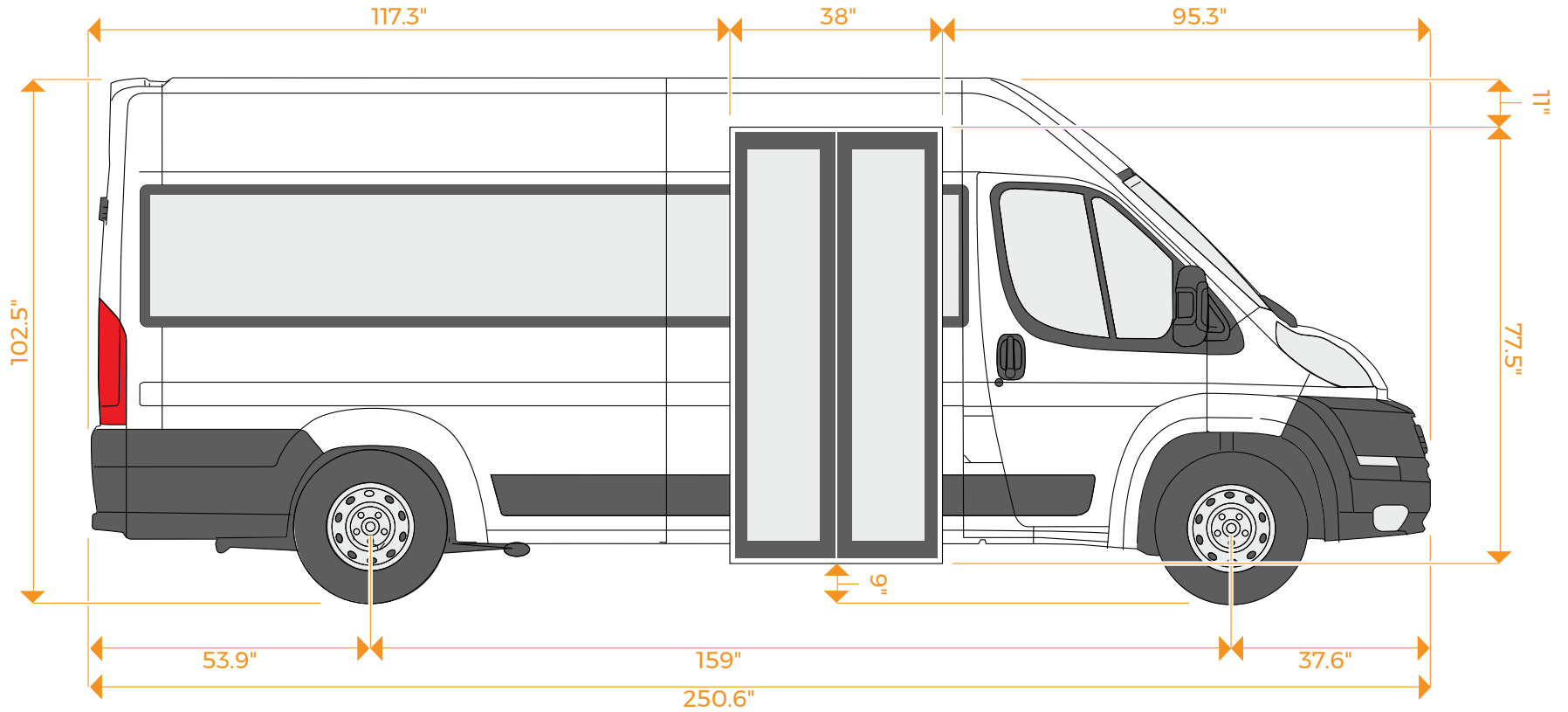

Note: Due to manufacturing tolerances both with the OEM vehicle and the conversion components, all dimensions may vary slightly from those shown.

Passenger Side Dimensions

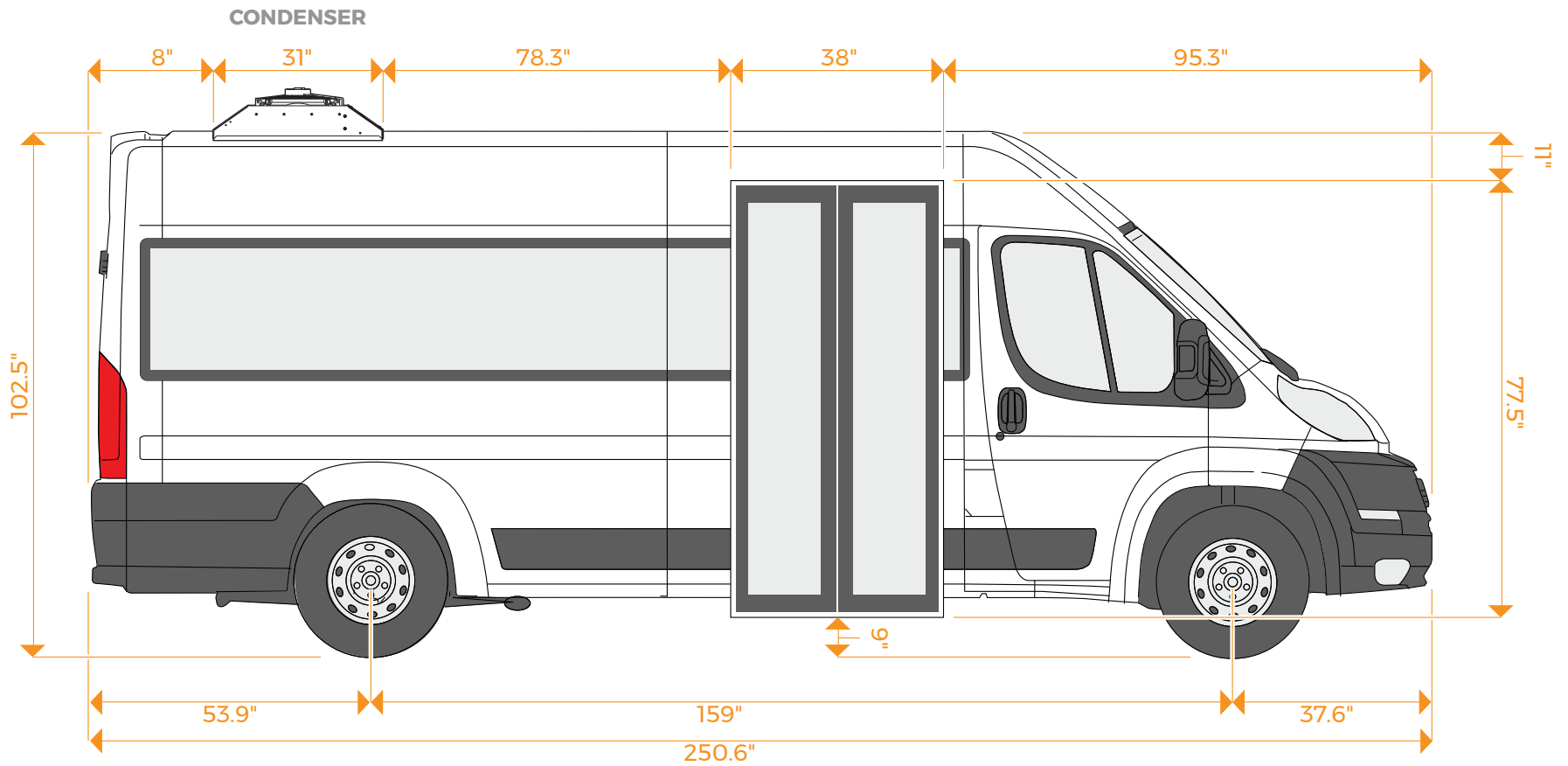

Note: Due to manufacturing tolerances both with the OEM vehicle and the conversion components, all dimensions may vary slightly from those shown.

Passenger Side Dimensions

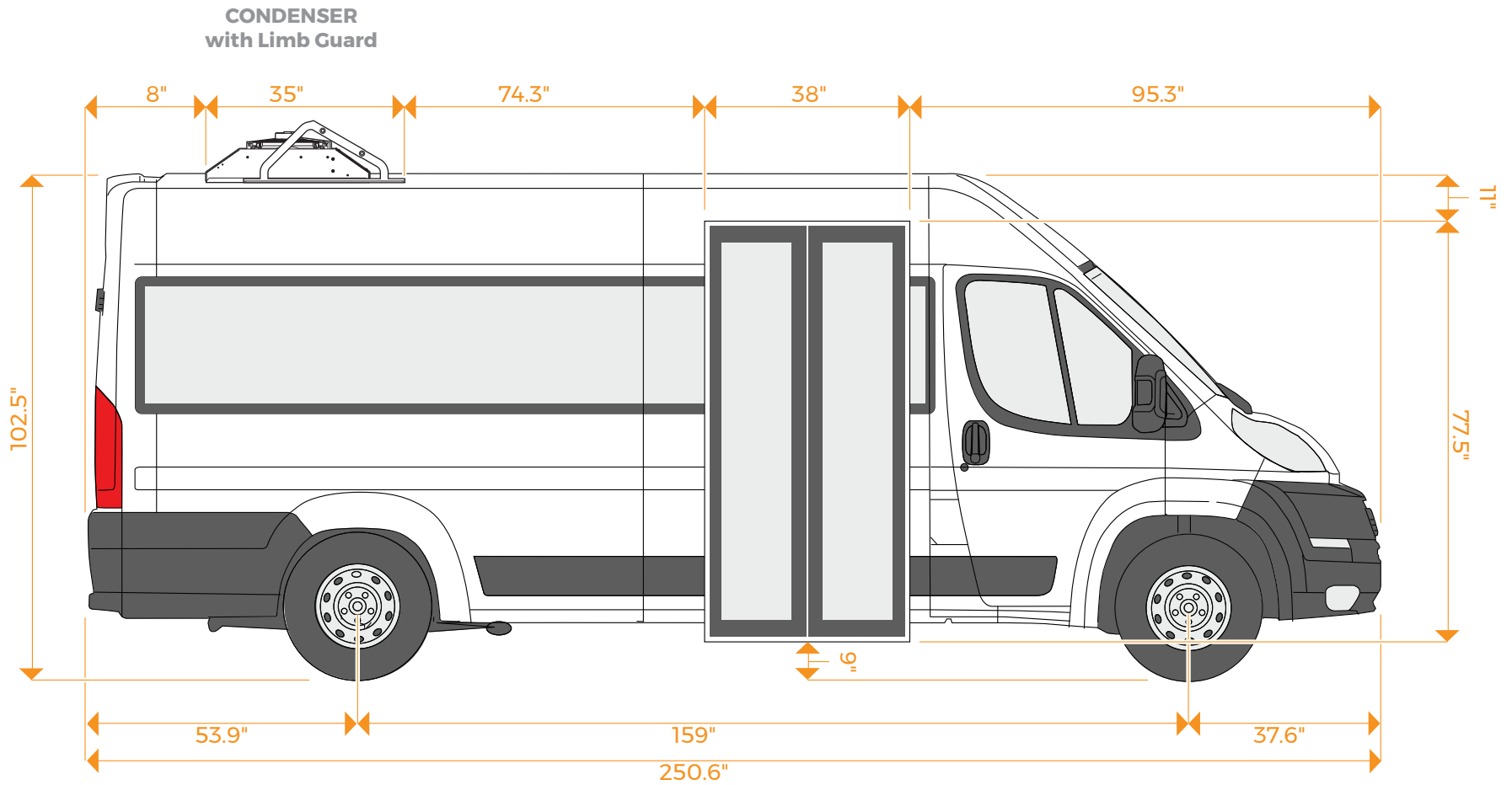

Note: Due to manufacturing tolerances both with the OEM vehicle and the conversion components, all dimensions may vary slightly from those shown.

Front Dimensions

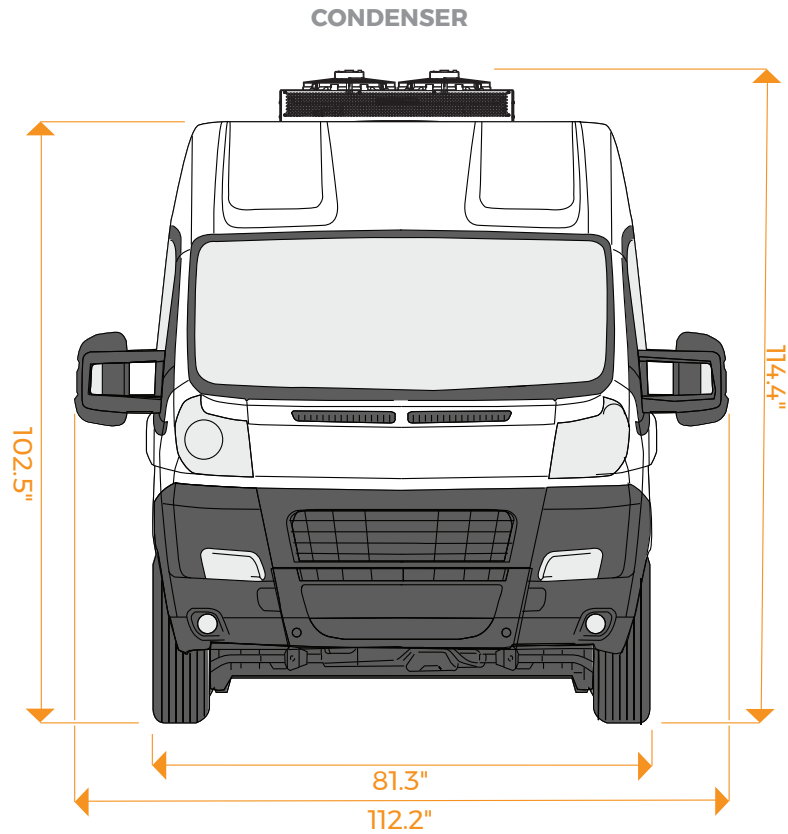

Rear Dimensions

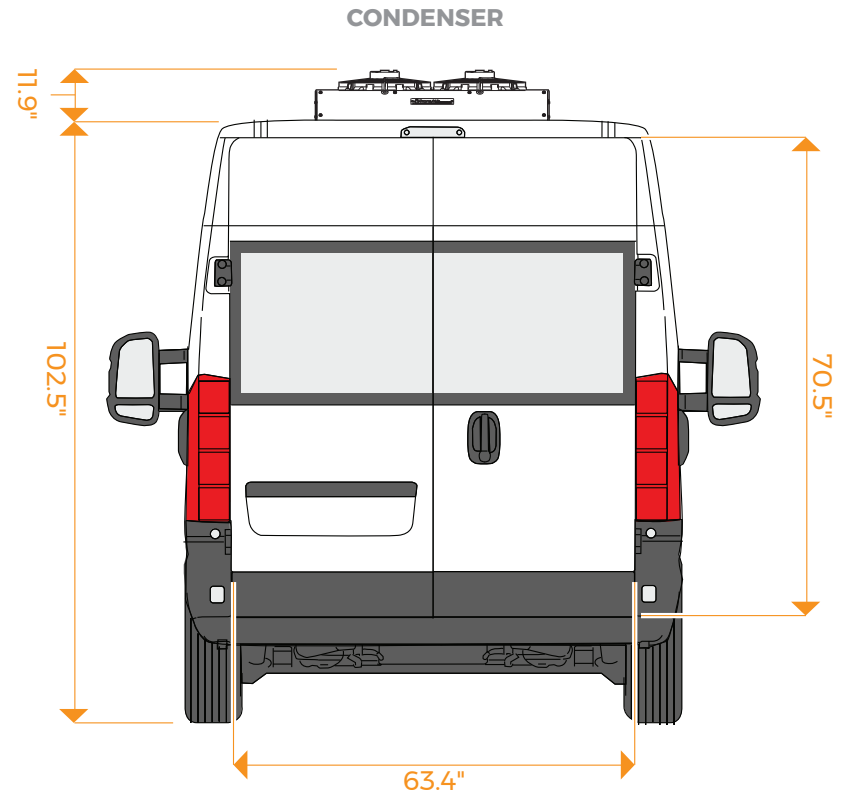

Note: Due to manufacturing tolerances both with the OEM vehicle and the conversion components, all dimensions may vary slightly from those shown.

Front Dimensions

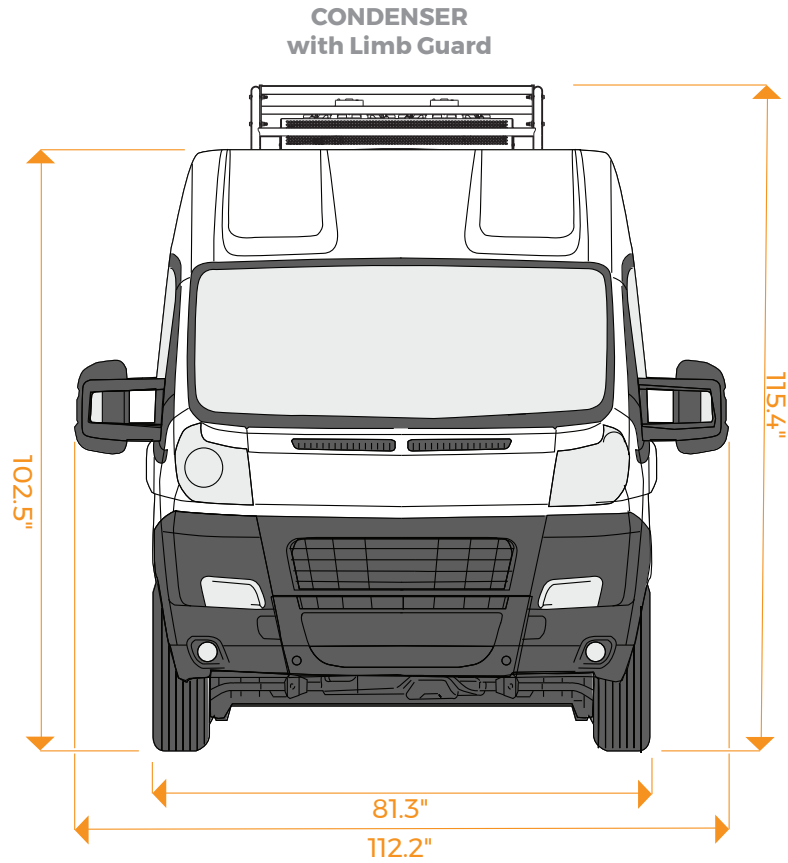

Rear Dimensions

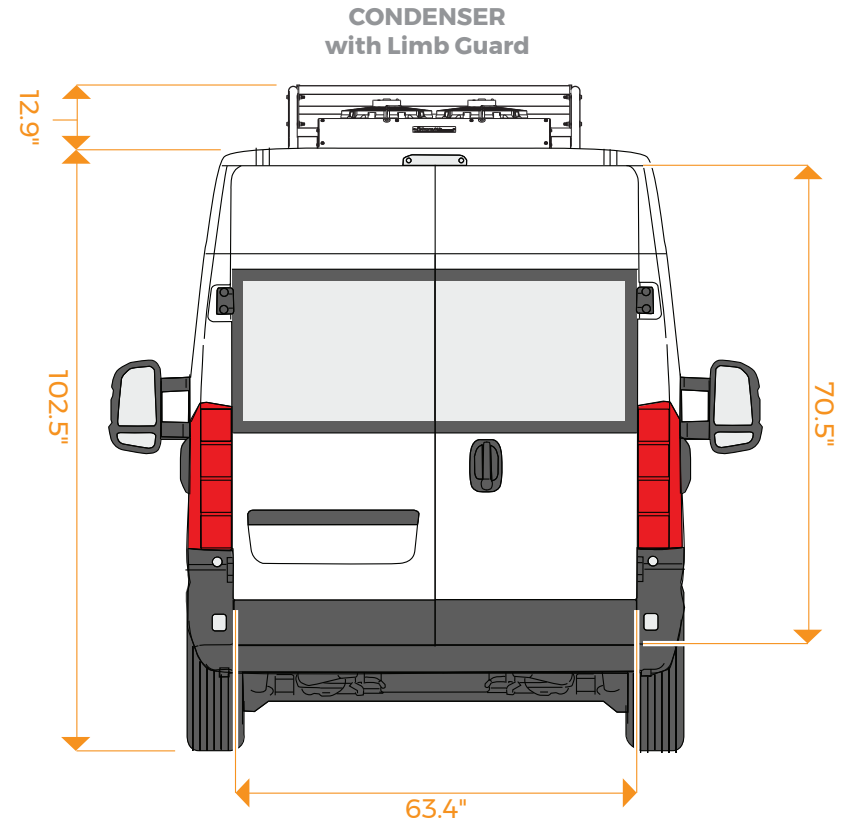

Note: Due to manufacturing tolerances both with the OEM vehicle and the conversion components, all dimensions may vary slightly from those shown.

Driver Side

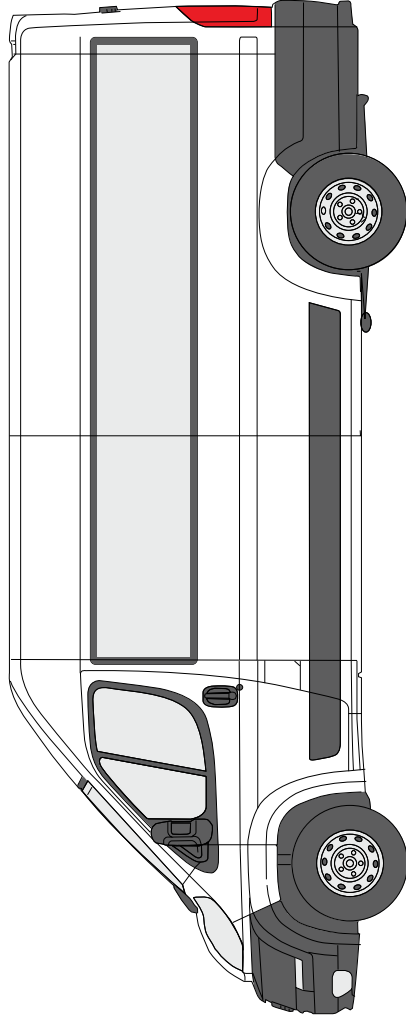

Front

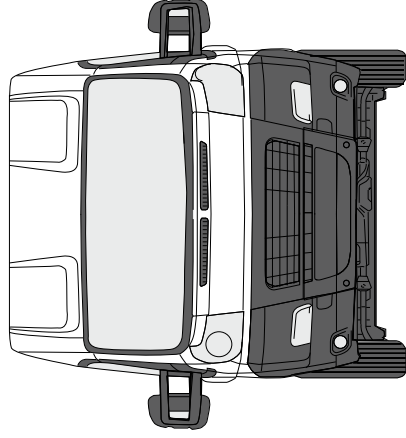

Passenger Side

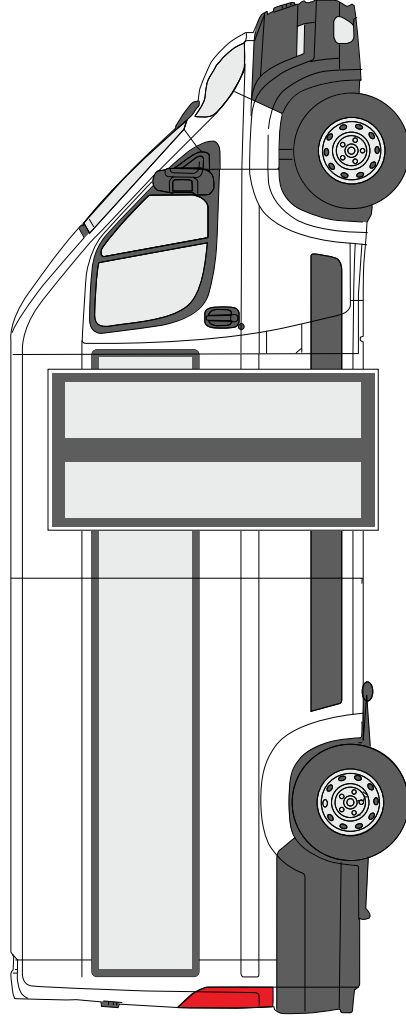

Rear

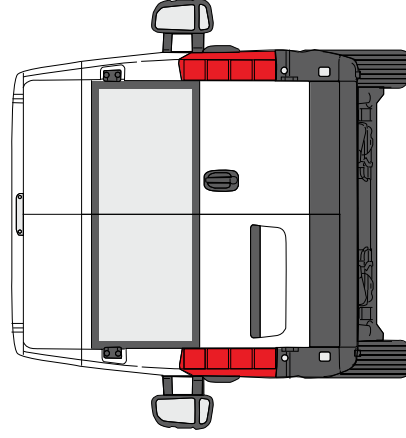

Driver Side Dimensions

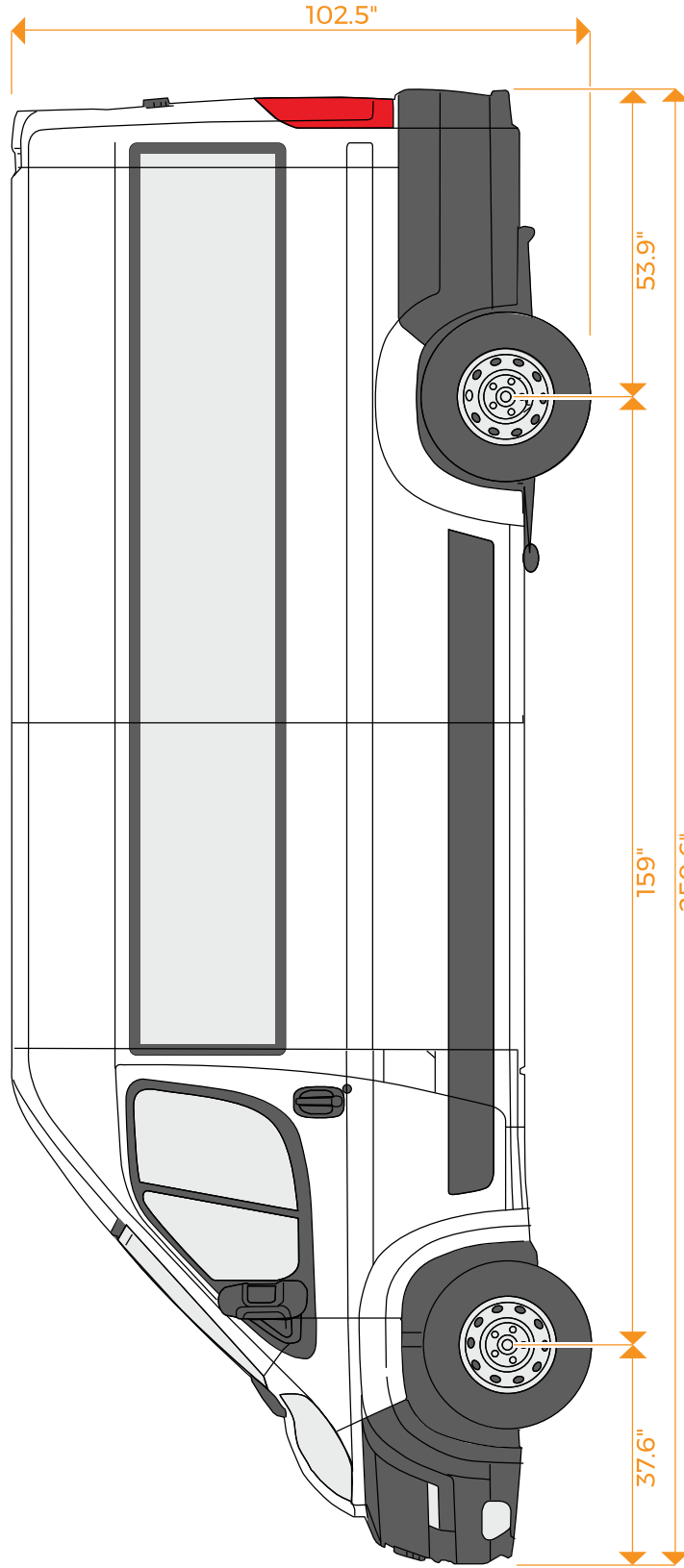

Note: Due to manufacturing tolerances both with the OEM vehicle and the conversion components, all dimensions may vary slightly from those shown.

Passenger Side Dimensions

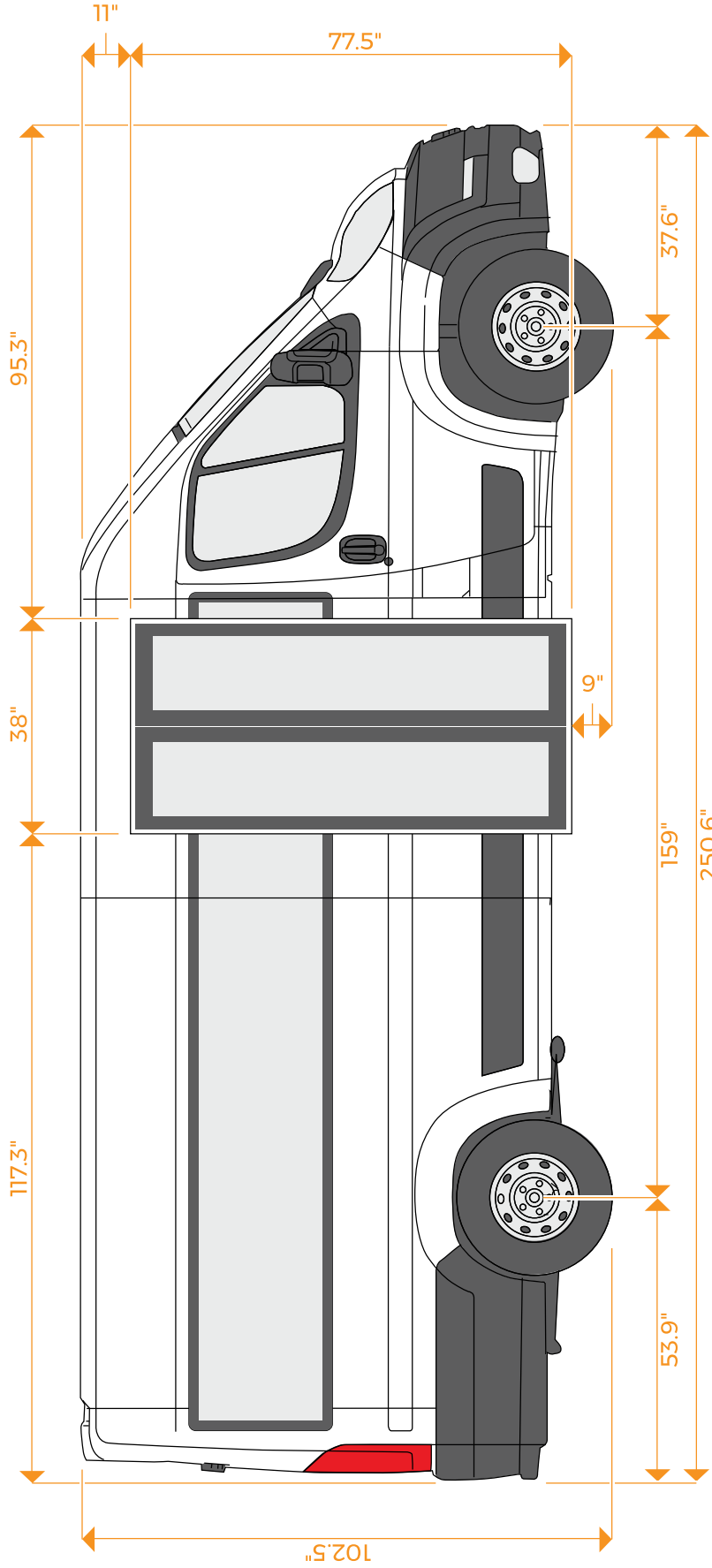

Note: Due to manufacturing tolerances both with the OEM vehicle and the conversion components, all dimensions may vary slightly from those shown.

Front Dimensions

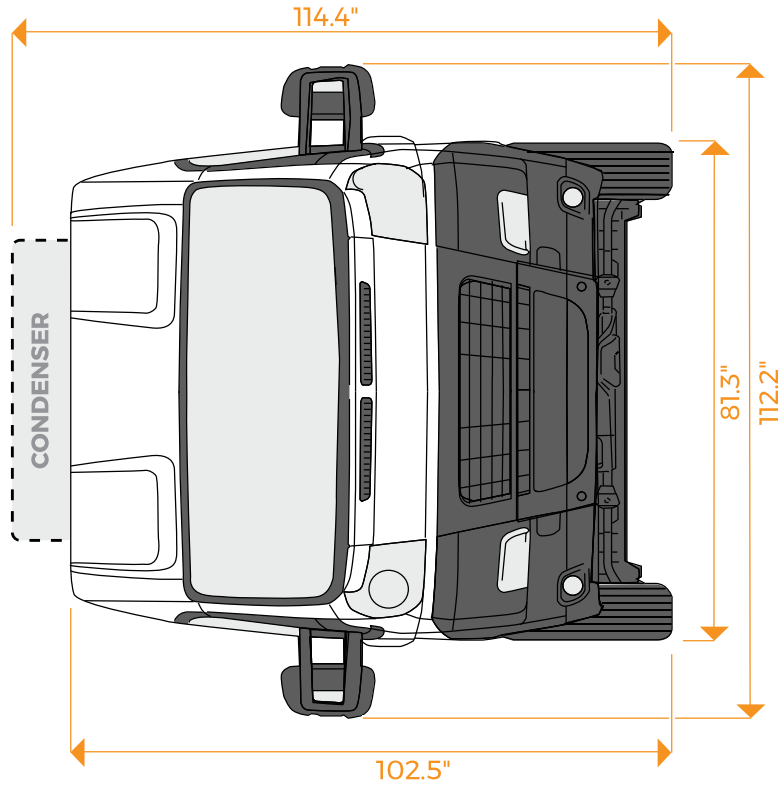

Rear Dimensions

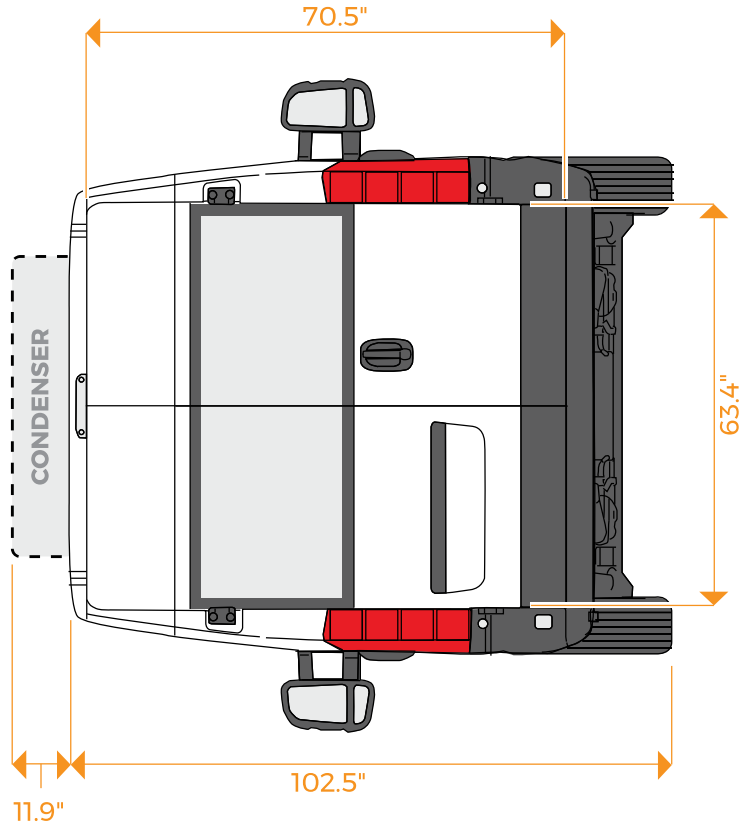

Note: Due to manufacturing tolerances both with the OEM vehicle and the conversion components, all dimensions may vary slightly from those shown.

TxDOT Form PTN-130

Texas Department of
Transportation Consolidated
Certification Form PTN-130

PTN-130 Form follows this page.



Consolidated Certification Form

This form is to assist subrecipients with managing the federal and state clauses related to the procurement they're interested in completing. This document complies with all pertinent federal and state regulations for each procurement type.

To begin, select the procurement's funding source. If TxDOT is the pass-through entity (Direct Recipient), both Federal and State must be checked.

Federal and State State Only

Federal Clauses – Procurement Types Summary:

All FTA-Assisted Third-Party Contracts and Subcontracts

1. No Federal Government Obligations to Third Parties
2. Access to Third Party Contract Records
3. Changes to Federal Requirements
4. Civil Rights (EEO, Title VI & ADA)
5. Incorporation of FTA Terms
6. Energy Conservation
7. Trafficking in Persons
8. False or Fraudulent Statements or Claims
9. Disadvantaged Business Enterprises (DBE)
10. Fly America
11. Americans with Disabilities Act (ADA) Access
12. Special Notification Requirements for States
13. Safe Operation of Motor Vehicles
14. Federal Tax Liability and Recent Felony Convictions
15. Program Fraud and False or Fraudulent Statements and Related Acts
16. Prompt Payment
17. Prohibition on Certain Telecommunications and Video Surveillance Services or Equipment
18. Conformance with Intelligent Transportation Systems (ITS) National Architecture
19. Severability

Award Exceeding \$10,000

20. Terminating the Contract
21. Solid Wastes

Award Exceeding \$25,000

22. Debarment and Suspension
23. Resolution of Disputes, Breaches, or Other Litigation

Award Exceeding \$50,000

24. Contracting with the Enemy

Award Exceeding \$100,000

25. Lobbying Restrictions

Award Exceeding \$150,000

26. Environmental Protection (Clean Air and Water Pollution Control)

All FTA-ASSISTED THIRD-PARTY CONTRACTS AND SUBCONTRACTS

1. No Federal Government Commitment or Liability to Third Parties

Except as the Federal Government expressly consents in writing, the Recipient agrees that:

- A. The Federal Government does not and shall not have any commitment or liability related to the Underlying Agreement, to any Third-Party Participant at any tier, or to any other person or entity that is not a party (FTA or the Recipient) to the Underlying Agreement; and
- B. Notwithstanding that the Federal Government may have concurred in or approved any Solicitation or Third-Party Agreement at any tier that may affect the Underlying Agreement, the Federal Government does not and shall not have any commitment or liability to any Third-Party Participant or other entity or person that is not a party (FTA or the Recipient) to the Underlying Agreement.

2. Access to Third-Party Contract Records

The Recipient agrees to require, and assures that each of its Subrecipients will require, its Third-Party Contractors at each tier to provide:

- A. The U.S. Secretary of Transportation and the Comptroller General of the United States, the state, or their duly authorized representatives, access to all Third-Party Contract records (at any tier) as required under 49 U.S.C. § 5325(g); and
- B. Sufficient access to all Third-Party Contract records (at any tier) as needed for compliance with applicable federal laws, regulations, and requirements or to assure.
- C. The Recipient will retain and will require its subcontractors of all tiers to retain, complete and readily accessible records related in whole or in part to the contract, including, but not limited to, data, documents, reports, statistics, leases, subcontracts, arrangements, other third-party Contracts of any type, and supporting materials related to those records.
- D. The Recipient agrees to comply with the record retention requirements in accordance with 2 C.F.R. § 200.334. The Contractor shall maintain all books, records, accounts, and reports required under this Contract for a period of at not less than three (3) years after the date of termination or expiration of this Contract, except in the event of litigation or settlement of claims arising from the performance of this Contract, in which case records shall be maintained until the disposition of all such litigation, appeals, claims or exceptions related thereto.

3. Changes to Federal Requirements

The Recipient agrees to include notice in each Third-Party Agreement that:

- A. Federal requirements that apply to the Recipient or the Award, the accompanying Underlying Agreement, and any Amendments thereto may change due to changes in federal law, regulation, other requirements, or guidance, or changes in the Recipient's Underlying Agreement including any information incorporated by reference and made part of that Underlying Agreement; and
- B. Applicable changes to those federal requirements will apply to each Third-Party Agreement and parties thereto at any tier.

4. Civil Rights

The Recipient agrees to apply these Federal Civil Rights laws and regulations apply to all contracts.

- A. Federal Equal Employment Opportunity (EEO) Requirements. These include, but are not limited to: a. Nondiscrimination in Federal Public Transportation Programs. 49 U.S.C. § 5332, covering projects, programs, and activities financed under 49 U.S.C. Chapter 53, prohibits discrimination on the basis of race, color, religion, national origin, sex (including sexual orientation and gender identity), disability, or age, and prohibits discrimination in employment or business opportunity. b. Prohibition against Employment Discrimination. Title VII of the Civil Rights Act of 1964, as amended, 42 U.S.C. § 2000e, and Executive Order No. 11246, "Equal Employment Opportunity," September 24, 1965, as amended, prohibit discrimination in employment on the basis of race, color, religion, sex, or national origin.

- B. Nondiscrimination on the Basis of Sex. Title IX of the Education Amendments of 1972, as amended, 20 U.S.C. § 1681 et seq. and implementing Federal regulations, "Nondiscrimination on the Basis of Sex in Education Programs or Activities Receiving Federal Financial Assistance," 49 C.F.R. part 25 prohibit discrimination on the basis of sex.
- C. Nondiscrimination on the Basis of Age. The "Age Discrimination Act of 1975," as amended, 42 U.S.C. § 6101 et seq., and Department of Health and Human Services implementing regulations, "Nondiscrimination on the Basis of Age in Programs or Activities Receiving Federal Financial Assistance," 45 C.F.R. part 90, prohibit discrimination by participants in federally assisted programs against individuals on the basis of age. The Age Discrimination in Employment Act (ADEA), 29 U.S.C. § 621 et seq., and Equal Employment Opportunity Commission (EEOC) implementing regulations, "Age Discrimination in Employment Act," 29 C.F.R. part 1625, also prohibit employment discrimination against individuals age 40 and over on the basis of age.
- D. Federal Protections for Individuals with Disabilities. The Americans with Disabilities Act of 1990, as amended (ADA), 42 U.S.C. § 12101 et seq., prohibits discrimination against qualified individuals with disabilities in programs, activities, and services, and imposes specific requirements on public and private entities. Third party contractors must comply with their responsibilities under Titles I, II, III, IV, and V of the ADA in employment, public services, public accommodations, telecommunications, and other provisions, many of which are subject to regulations issued by other Federal agencies.
- E. Equal Opportunity: The Agency is an Equal Opportunity Employer. As such, the Agency agrees to comply with all applicable Federal civil rights laws and implementing regulations. Apart from inconsistent requirements imposed by Federal laws or regulations, the Agency agrees to comply with the requirements of 49 U.S.C. § 5323(h) (3) by not using any Federal assistance awarded by FTA to support procurements using exclusionary or discriminatory specifications. Under this Contract, the Contractor shall at all times comply with the following requirements and shall include these requirements in each subcontract entered into as part thereof.
- I. Nondiscrimination. In accordance with Federal transit law at 49 U.S.C. § 5332, the Contractor agrees that it will not discriminate against any employee or applicant for employment because of race, color, religion, national origin, sex, disability, or age. In addition, the Contractor agrees to comply with applicable Federal implementing regulations and other implementing requirements FTA may issue.
- II. Race, Color, Religion, National Origin, Sex. In accordance with Title VII of the Civil Rights Act, as amended, 42 U.S.C. § 2000e et seq., and Federal transit laws at 49 U.S.C. § 5332, the Contractor agrees to comply with all applicable equal employment opportunity requirements of U.S. Department of Labor (U.S. DOL) regulations, "Office of Federal Contract Compliance Programs, Equal Employment Opportunity, Department of Labor," 41 C.F.R. chapter 60, and Executive Order No. 11246, "Equal Employment Opportunity in Federal Employment," September 24, 1965, 42 U.S.C. § 2000e note, as amended by any later Executive Order that amends or supersedes it, referenced in 42 U.S.C. § 2000e note. The Contractor agrees to take affirmative action to ensure that applicants are employed, and that employees are treated during employment, without regard to their race, color, religion, national origin, or sex (including sexual orientation and gender identity). Such action shall include, but not be limited to, the following: employment, promotion, demotion or transfer, recruitment or recruitment advertising, layoff or termination; rates of pay or other forms of compensation; and selection for training, including apprenticeship. In addition, the Contractor agrees to comply with any implementing requirements FTA may issue.
- III. Age. In accordance with the Age Discrimination in Employment Act, 29 U.S.C. §§ 621-634, U.S. Equal Employment Opportunity Commission (U.S. EEOC) regulations, "Age Discrimination in Employment Act," 29 C.F.R. part 1625, the Age Discrimination Act of 1975, as amended, 42 U.S.C. § 6101 et seq., U.S. Health and Human Services regulations, "Nondiscrimination on the Basis of Age in Programs or Activities Receiving Federal Financial Assistance," 45 C.F.R. part 90, and Federal transit law at 49 U.S.C. § 5332, the Contractor agrees to refrain from discrimination against present and prospective employees for reason of age. In addition, the Contractor agrees to comply with any Implementing requirements FTA may issue.
- IV. Disabilities. In accordance with section 504 of the Rehabilitation Act of 1973, as amended, 29 U.S.C. § 794, the Americans with Disabilities Act of 1990, as amended, 42 U.S.C. § 12101 et seq., the Architectural Barriers Act of 1968, as amended, 42 U.S.C. § 4151 et seq., and Federal transit law at 49 U.S.C. § 5332, the Contractor agrees that it will not discriminate against individuals on the basis of disability. In addition, the Contractor agrees to comply with any implementing requirements FTA may issue.
- V. Promoting Free Speech and Religious Liberty. The Contractor shall ensure that Federal funding is expended in full accordance with the U.S. Constitution, Federal Law, and statutory and public policy requirements: including, but not limited to, those protecting free speech, religious liberty, public welfare, the environment, and prohibiting discrimination.

5. Incorporation of Federal Transit Administration (FTA) Terms

The provisions within include, in part, certain Standard Terms and Conditions required by DOT, whether or not expressly set forth

in the preceding contract provisions. All contractual provisions required by DOT, as set forth in the current FTA Circular 4220 are hereby incorporated by reference. Anything to the contrary herein notwithstanding, all FTA mandated terms shall be deemed to control in the event of a conflict with other provisions contained in this Contract. The Contractor shall not perform any act, fail to perform any act, or refuse to comply with any request which would cause a violation of the FTA terms and conditions.

6. Energy Conservation

The Recipient agrees to, and assures that its Subrecipients will, comply with the mandatory energy standards and policies of its state energy conservation plans under the Energy Policy and Conservation Act, as amended, 42 U.S.C. § 6321 et seq., and perform an energy assessment for any building constructed, reconstructed, or modified with federal assistance required under FTA regulations, "Requirements for Energy Assessments," 49 C.F.R. part 622, subpart C.

7. Trafficking in Persons

The contractor agrees that it and its employees that participate in the Recipient's Award, may not:

- A. Engage in severe forms of trafficking in persons during the period of time that the Recipient's Award is in effect;
- B. Procure a commercial sex act during the period of time that the Recipient's Award is in effect; or
- C. Use forced labor in the performance of the Recipient's Award or subagreements thereunder.

8. False or Fraudulent Statements or Claims

A. Civil Fraud. The Recipient acknowledges and agrees that:

- I. Federal laws, regulations, and requirements apply to itself and its Underlying Agreement, including the Program Fraud Civil Remedies Act of 1986, as amended, 31 U.S.C. § 3801 et seq., and U.S. DOT regulations, "Program Fraud Civil Remedies," 49 C.F.R. part 31.
- II. By executing the Underlying Agreement, the Recipient certifies and affirms to the Federal Government the truthfulness and accuracy of any claim, statement, submission, certification, assurance, affirmation, or representation that the Recipient provides to the Federal Government.
- III. The Federal Government may impose the penalties of the Program Fraud Civil Remedies Act of 1986, as amended, and other applicable penalties if the Recipient presents, submits, or makes available any false, fictitious, or fraudulent information.

B. Criminal Fraud. The Recipient acknowledges that 49 U.S.C. § 5323(l)(1) authorizes the Federal Government to impose the penalties under 18 U.S.C. § 1001 if the Recipient provides a false, fictitious, or fraudulent claim, statement, submission, certification, assurance, or representation in connection with a federal public transportation program under 49 U.S.C. chapter 53 or any other applicable federal law.

9. Disadvantaged Business Enterprises

The contractor or subcontractor shall not discriminate on the basis of race, color, national origin, or sex in the performance of this contract. The contractor shall carry out applicable requirements of 49 C.F.R. part 26 in the award and administration of DOT-assisted contracts. Failure by the contractor to carry out these requirements is a material breach of this contract, which may result in the termination of this contract or such other remedy as the recipient deems appropriate, which may include, but is not limited to:

- A. Withholding monthly progress payments;
- B. Assessing sanctions;

C. Liquidated damages; and/or

D. Disqualifying the contractor from future bidding as non-responsible. 49 C.F.R. §26.13(b).

In accordance with 49 C.F.R. § 26.29(a), Prime contractors agree to pay subcontractors for satisfactory performance of their contracts no later than 30 days from receipt of each payment the recipient makes to the prime contractor using direct federal funds, and no later than 10 days from receipt of payment the recipient makes to the prime contractor using state or federal funds pass-through the Texas Department of Transportation (TxDOT) per TxDOT policy.

Finally, for contracts with defined DBE contract goals, each FTA recipient must include in each prime contract a provision stating that the contractor shall utilize the specific DBEs listed unless the contractor obtains the recipient's written consent; and that, unless the recipient's consent is provided, the contractor shall not be entitled to any payment for work or material unless it is performed or supplied by the listed DBE. 49 C.F.R. § 26.53(f)(1).

10. Fly America

The recipient agrees to comply with the air transportation requirements of Section 5 of the International Air Transportation Fair Competitive Practices Act of 1974, as amended, 49 U.S.C. § 40118, and U.S. General Services Administration (U.S. GSA) regulations, "Use of United States Flag Air Carriers," 41 C.F.R. §§ 301-10.131 – 301-10.143.

11. ADA Access

The Recipient agrees to comply with the following federal prohibitions against discrimination based on disability:

A. Federal laws, including:

- I. Section 504 of the Rehabilitation Act of 1973, as amended, 29 U.S.C. § 794, which prohibits discrimination based on disability in the administration of federally assisted Programs, Projects, or activities;
- II. The Americans with Disabilities Act of 1990 (ADA), as amended, 42 U.S.C. § 12101 et seq., which requires that accessible facilities and services be made available to individuals with disabilities:
 - a. For FTA Recipients generally, Titles I, II, and III of the ADA apply; but
 - b. For Indian Tribes, Titles II and III of the ADA apply, but Title I of the ADA does not apply because it exempts Indian Tribes from the definition of "employer;"
- III. The Architectural Barriers Act of 1968, as amended, 42 U.S.C. § 4151 et seq., which requires that buildings and public accommodations be accessible to individuals with disabilities;
- IV. Federal transit law, specifically 49 U.S.C. § 5332, which now includes disability as a prohibited basis for discrimination; and
- V. Other applicable federal laws, regulations, and requirements pertaining to access for seniors or individuals with disabilities.

B. Federal regulations and guidance, including:

- I. U.S. DOT regulations, "Transportation Services for Individuals with Disabilities (ADA)," 49 C.F.R. part 37;
- II. U.S. DOT regulations, "Nondiscrimination on the Basis of Disability in Programs and Activities Receiving or Benefiting from Federal Financial Assistance," 49 C.F.R. part 27;
- III. Joint U.S. Architectural and Transportation Barriers Compliance Board (U.S. ATBCB) and U.S. DOT regulations, "Americans With Disabilities (ADA) Accessibility Specifications for Transportation Vehicles," 36 C.F.R. part 1192 and 49 C.F.R. part 38;
- IV. U.S. DOT regulations, "Transportation for Individuals with Disabilities: Passenger Vessels," 49 C.F.R. part 39;
- V. U.S. DOJ regulations, "Nondiscrimination on the Basis of Disability in State and Local Government Services," 28 C.F.R. part 35;
- VI. U.S. DOJ regulations, "Nondiscrimination on the Basis of Disability by Public Accommodations and in Commercial Facilities," 28 C.F.R. part 36;
- VII. U.S. EEOC, "Regulations to Implement the Equal Employment Provisions of the Americans with Disabilities Act," 29 C.F.R.

part 1630;

VIII. U.S. Federal Communications Commission regulations, "Telecommunications Relay Services and Related Customer Premises Equipment for Persons with Disabilities," 47 C.F.R. part 64, subpart F;

IX. U.S. ATBCB regulations, "Electronic and Information Technology Accessibility Standards," 36 C.F.R. part 1194;

X. FTA regulations, "Transportation for Elderly and Handicapped Persons," 49 C.F.R. part 609;

XI. FTA Circular 4710.1, "Americans with Disabilities Act: Guidance;" and

XII. Other applicable federal civil rights and nondiscrimination regulations and guidance.

12. Special Notification Requirements for States

A. Types of Information. To the extent required under federal law, the State, as the Recipient, agrees to provide the following information about federal assistance awarded for its State Program, Project, or related activities:

I. The Identification of FTA as the federal agency providing the federal assistance for a State Program or Project;

II. The Catalog of Federal Domestic Assistance Number of the program from which the federal assistance for a State Program or Project is authorized; and

III. The amount of federal assistance FTA has provided for a State Program or Project.

B. Documents. The State agrees to provide the information required under this provision in the following documents: (1) applications for federal assistance, (2) requests for proposals or solicitations, (3) forms, (4) notifications, (5) press releases, and (6) other publications.

13. Safe Operation of Motor Vehicles

Seat Belt Use

The Contractor is encouraged to adopt and promote on-the-job seat belt use policies and programs for its employees and other personnel that operate company-owned vehicles, company rented vehicles, or personally operated vehicles. The terms "company-owned" and "company-leased" refer to vehicles owned or leased either by the Contractor or Agency.

Distracted Driving

The Contractor agrees to adopt and enforce workplace safety policies to decrease crashes caused by distracted drivers, including policies to ban text messaging while using an electronic device supplied by an employer, and driving a vehicle the driver owns or rents, a vehicle Contractor owns, leases, or rents, or a privately-owned vehicle when on official business in connection with the work performed under this Contract.

14. Federal Tax Liability and Recent Felony Convictions

A. The contractor certifies that it:

I. Does not have any unpaid Federal tax liability that has been assessed, for which all judicial and administrative remedies have been exhausted or have lapsed, and that is not being paid in a timely manner pursuant to an agreement with the authority responsible for collecting the tax liability; and

II. Was not convicted of the felony criminal violation under any Federal law within the preceding 24 months.

If the contractor cannot so certify, the Recipient will refer the matter to FTA and not enter into any Third-Party Agreement with the Third-Party Participant without FTA's written approval.

B. Flow Down

I. The Recipient agrees to require the contractor to flow this requirement down to participants at all lower tiers, without regard to the value of any subagreement.

15. Program Fraud and False or Fraudulent Statements and Related Acts

The Contractor acknowledges that the provisions of the Program Fraud Civil Remedies Act of 1986, as amended, 31 U.S.C. § 3801 et seq. and U.S. DOT regulations, "Program Fraud Civil Remedies," 49 C.F.R. part 31, apply to its actions pertaining to this Project. Upon execution of the underlying contract, the Contractor certifies or affirms the truthfulness and accuracy of any statement it

has made, it makes, it may make, or causes to be made, pertaining to the underlying contract or the FTA assisted project for which this contract work is being performed. In addition to other penalties that may be applicable, the Contractor further acknowledges that if it makes, or causes to be made, a false, fictitious, or fraudulent claim, statement, submission, or certification, the Federal Government reserves the right to impose the penalties of the Program Fraud Civil Remedies Act of 1986 on the Contractor to the extent the Federal Government deems appropriate.

The Contractor also acknowledges that if it makes, or causes to be made, a false, fictitious, or fraudulent claim, statement, submission, or certification to the Federal Government under a contract connected with a project that is financed in whole or in part with Federal assistance originally awarded by FTA under the authority of 49 U.S.C. chapter 53, the Government reserves the right to impose the penalties of 18 U.S.C. § 1001 and 49 U.S.C. § 5323(l) on the Contractor, to the extent the Federal Government deems appropriate.

The Contractor agrees to include the above two clauses in each subcontract financed in whole or in part with Federal assistance provided by FTA. It is further agreed that the clauses shall not be modified, except to identify the subcontractor who will be subject to the provisions.

16. Prompt Payment

The contractor is required to pay its subcontractors performing work related to this contract for satisfactory performance of that work no later than 30 days after the contractor's receipt of payment for that work. Per Texas Department of Transportation (TxDOT) policy, the 30-day payment window is reduced to 10-days from receipt of payment when the contractor is using state or federal funds pass-through TxDOT to reimburse subcontractors. In addition, the contractor is required to return any retainage payments to those subcontractors within 30 days after the subcontractor's work related to this contract is satisfactorily completed. The contractor must promptly notify the Agency, whenever a DBE subcontractor performing work related to this contract is terminated or fails to complete its work and must make good faith efforts to engage another DBE subcontractor to perform at least the same amount of work. The contractor may not terminate any DBE subcontractor and perform that work through its own forces or those of an affiliate without prior written consent of the Agency.

17. Prohibition on certain telecommunications and video surveillance services or equipment

Recipients and subrecipients are prohibited from obligating or expending loan or grant funds to:

- A. Procure or obtain;
- B. Extend or renew a contract to procure or obtain; or
- C. Enter into a contract (or extend or renew a contract) to procure or obtain equipment, services, or systems that uses covered telecommunications equipment or services as a substantial or essential component of any system, or as critical technology as part of any system. As described in Public Law 115-232, section 889, covered telecommunications equipment is telecommunications equipment produced by Huawei Technologies Company or ZTE Corporation (or any subsidiary or affiliate of such entities).
- E. For the purpose of public safety, security of government facilities, physical security surveillance of critical infrastructure, and other national security purposes, video surveillance and telecommunications equipment produced by Hytera Communications Corporation, Hangzhou Hikvision Digital Technology Company, or Dahua Technology Company (or any subsidiary or affiliate of such entities).
- D. Telecommunications or video surveillance services provided by such entities or using such equipment.
- E. Telecommunications or video surveillance equipment or services produced or provided by an entity that the Secretary of Defense, in consultation with the Director of the National Intelligence or the Director of the Federal Bureau of Investigation, reasonably believes to be an entity owned or controlled by, or otherwise connected to, the government of a covered foreign country.

In implementing the prohibition under Public Law 115-232, section 889, subsection (f), paragraph (1), heads of executive agencies administering loan, grant, or subsidy programs shall prioritize available funding and technical support to assist affected businesses, institutions and organizations as is reasonably necessary for those affected entities to transition from covered communications equipment and services, to procure replacement equipment and services, and to ensure that communications service to users and customers is sustained.

18. Conformance with ITS National Architecture

Intelligent Transportation Systems (ITS) projects shall conform to the National ITS Architecture and standards pursuant to 23 CFR § 940. Conformance with the National ITS Architecture is interpreted to mean the use of the National ITS Architecture to develop a

regional ITS architecture in support of integration and the subsequent adherence of all ITS projects to that regional ITS architecture. Development of the regional ITS architecture should be consistent with the transportation planning process for Statewide and Metropolitan Transportation Planning (49 CFR Part 613 and 621).

19. Severability

The Contractor agrees that if any provision of this agreement or any amendment thereto is determined to be invalid, then the remaining provisions thereof that conform to federal laws, regulations, requirements, and guidance will continue in effect.

Awards Exceeding \$10,000

20. Termination

A. Termination for Convenience

The Agency may terminate this contract, in whole or in part, at any time by written notice to the Contractor when it is in the Agency's best interest. The Contractor shall be paid its costs, including contract closeout costs, and profit on work performed up to the time of termination. The Contractor shall promptly submit its termination claim to Agency to be paid the Contractor. If the Contractor has any property in its possession belonging to Agency, the Contractor will account for the same, and dispose of it in the manner Agency directs.

B. Termination for Default [Breach or Cause]

If the Contractor does not deliver supplies in accordance with the contract delivery schedule, or if the contract is for services, the Contractor fails to perform in the manner called for in the contract, or if the Contractor fails to comply with any other provisions of the contract, the Agency may terminate this contract for default. Termination shall be effected by serving a Notice of Termination on the Contractor setting forth the manner in which the Contractor is in default. The Contractor will be paid only the contract price for supplies delivered and accepted, or services performed in accordance with the manner of performance set forth in the contract. If it is later determined by the Agency that the Contractor had an excusable reason for not performing, such as a strike, fire, or flood, events which are not the fault of or are beyond the control of the Contractor, the Agency, after setting up a new delivery of performance schedule, may allow the Contractor to continue work, or treat the termination as a Termination for Convenience.

C. Opportunity to Cure

The Agency, in its sole discretion may, in the case of a termination for breach or default, allow the Contractor [an appropriately short period of time] in which to cure the defect. In such case, the Notice of Termination will state the time period in which cure is permitted and other appropriate conditions.

If Contractor fails to remedy to Agency's satisfaction the breach or default of any of the terms, covenants, or conditions of this Contract within [10 days] after receipt by Contractor of written notice from Agency setting forth the nature of said breach or default, Agency shall have the right to terminate the contract without any further obligation to Contractor. Any such termination for default shall not in any way operate to preclude Agency from also pursuing all available remedies against Contractor and its sureties for said breach or default.

D. Waiver of Remedies for any Breach

In the event that Agency elects to waive its remedies for any breach by Contractor of any covenant, term or condition of this contract, such waiver by Agency shall not limit Agency's remedies for any succeeding breach of that or of any other covenant, term, or condition of this contract.

21. Solid Wastes

A Recipient that is a state agency or agency of a political subdivision of a state and its contractors must comply with section 6002 of the Solid Waste Disposal Act, as amended by the Resource Conservation and Recovery Act. The requirements of Section 6002 include procuring only items designated in guidelines of the Environmental Protection Agency (EPA) at 40 CFR Part 247 that contain the highest percentage of recovered materials practicable, consistent with maintaining a satisfactory level of competition, where the purchase price of the item exceeds \$10,000 or the value of the quantity acquired during the preceding fiscal year exceeded \$10,000; procuring solid waste management services in a manner that maximizes energy and resource recovery; and

establishing an affirmative procurement program for procurement of recovered materials identified in the EPA guidelines.

Awards Exceeding \$25,000

22. Debarment and Suspension

The Recipient agrees to the following:

- A. It will comply with the following requirements of 2 C.F.R. part 180, subpart C, as adopted and supplemented by U.S. DOT regulations at 2 C.F.R. part 1200.
- B. It will not enter into any “covered transaction” (as that phrase is defined at 2 C.F.R. §§ 180.220 and 1200.220) with any Third-Party Participant that is, or whose principal is, suspended, debarred, or otherwise excluded from participating in covered transactions, except as authorized by—
 - I. U.S. DOT regulations, “Nonprocurement Suspension and Debarment,” 2 C.F.R. part 1200;
 - II. U.S. OMB regulatory guidance, “Guidelines to Agencies on Governmentwide Debarment and Suspension (Nonprocurement),” 2 C.F.R. part 180; and
 - III. Other applicable federal laws, regulations, or requirements regarding participation with debarred or suspended Recipients or Third-Party Participants.
- C. It will review the U.S. GSA “System for Award Management – Lists of Parties Excluded from Federal Procurement and Nonprocurement Programs,” if required by U.S. DOT regulations, 2 C.F.R. part 1200.
- D. It will ensure that its Third-Party Agreements contain provisions necessary to flow down these suspension and debarment provisions to all lower tier covered transactions.
- E. If the Recipient suspends, debars, or takes any similar action against a Third-Party Participant or individual, the Recipient will provide immediate written notice to the:
 - I. FTA Regional Counsel for the Region in which the Recipient is located or implements the Underlying Agreement;
 - II. FTA Headquarters Manager that administers the Grant or Cooperative Agreement; or
 - III. FTA Chief Counsel.

23. Resolution of Disputes, Breaches, or Other Litigation

A. FTA Interest

FTA has a vested interest in the settlement of any violation of federal law, regulation, or requirement, or any disagreement involving the Award, the accompanying Underlying Agreement, and any Amendments thereto including, but not limited to, a default, breach, major dispute, or litigation, and FTA reserves the right to concur in any settlement or compromise.

B. Notification to FTA; Flow Down Requirement

If a current or prospective legal matter that may affect the Federal Government emerges, the Recipient must promptly notify the FTA Chief Counsel and FTA Regional Counsel for the Region in which the Recipient is located. The Recipient must include a similar notification requirement in its Third-Party Agreements and must require each Third-Party Participant to include an equivalent provision in its sub-agreements at every tier, for any agreement that is a “covered transaction” according to 2 C.F.R. §§ 180.220 and 1200.220.

- I. The types of legal matters that require notification include, but are not limited to, a major dispute, breach, default, litigation, or naming the Federal Government as a party to litigation or a legal disagreement in any forum for any reason.
- II. Matters that may affect the Federal Government include, but are not limited to, the Federal Government's interests in the Award, the accompanying Underlying Agreement, and any Amendments thereto, or the Federal Government's administration or enforcement of federal laws, regulations, and requirements.
- III. Additional Notice to U.S. DOT Inspector General. The Recipient must promptly notify the U.S. DOT Inspector General in

addition to the FTA Chief Counsel or Regional Counsel for the Region in which the Recipient is located, if the Recipient has knowledge of potential fraud, waste, or abuse occurring on a Project receiving assistance from FTA. The notification provision applies if a person has or may have submitted a false claim under the False Claims Act, 31 U.S.C. § 3729 et seq., or has or may have committed a criminal or civil violation of law pertaining to such matters as fraud, conflict of interest, bid rigging, misappropriation or embezzlement, bribery, gratuity, or similar misconduct involving federal assistance. This responsibility occurs whether the Project is subject to this Agreement or another agreement between the Recipient and FTA, or an agreement involving a principal, officer, employee, agent, or Third-Party Participant of the Recipient. It also applies to subcontractors at any tier. Knowledge, as used in this paragraph, includes, but is not limited to, knowledge of a criminal or civil investigation by a Federal, state, or local law enforcement or other investigative agency, a criminal indictment or civil complaint, or probable cause that could support a criminal indictment, or any other credible information in the possession of the Recipient. In this paragraph, "promptly" means to refer information without delay and without change. This notification provision applies to all divisions of the Recipient, including divisions tasked with law enforcement or investigatory functions.

C. Federal Interest in Recovery

The Federal Government retains the right to a proportionate share of any proceeds recovered from any third party, based on the percentage of the federal share for the Underlying Agreement. Notwithstanding the preceding sentence, the Recipient may return all liquidated damages it receives to its Award Budget for its Underlying Agreement rather than return the federal share of those liquidated damages to the Federal Government, provided that the Recipient receives FTA's prior written concurrence.

D. Enforcement

The Recipient must pursue its legal rights and remedies available under any Third-Party Agreement or any federal, state, or local law or regulation.

E. Agency Process

*Vendors may view the dispute resolution process here:

Procurement Grievance Procedures

Any bidder may file a grievance with SPCAA following a competitive bidding process. Once a selection is made, bidders must be notified in writing of the results. The written communication mailed to bidders must also inform them that they may have a right to appeal the decision. Information on the organization's appeal procedures must be made available to all prospective contractors or subgrantees upon request, including the name and address of a contact person, and a deadline for filing the grievance. Grievances are limited to violations of federal laws or regulations, or failure of the Organization to follow its own procurement policies.

Grievances can be mailed at the following address:

SPCAA
PO BOX 610
Levelland, TX 79336

Awards Exceeding \$50,000

24. Never Contract with the Enemy

The Recipient agrees to the regulations implementing Never Contract with the Enemy in 2 CFR part 183. The regulations in 2 CFR part 183 affect covered contracts, grants and cooperative agreements that are expected to exceed \$50,000 within the period of performance, are performed outside the United States and its territories, and are in support of a contingency operation in which members of the Armed Forces are actively engaged in hostilities.

Awards Exceeding \$100,000

25. Lobbying Restrictions.

The Recipient agrees that neither it nor any Third-Party Participant will use federal assistance to influence any officer or employee

of a federal agency, member of Congress or an employee of a member of Congress, or officer or employee of Congress on matters that involve the Underlying Agreement, including any extension or modification, according to the following:

A. Laws, Regulations, Requirements, and Guidance. This includes:

- I. The Byrd Anti-Lobbying Amendment, 31 U.S.C. § 1352, as amended;
- II. U.S. DOT regulations, "New Restrictions on Lobbying," 49 C.F.R. part 20, to the extent consistent with 31 U.S.C. § 1352, as amended; and
- III. Other applicable federal laws, regulations, requirements, and guidance prohibiting the use of federal assistance for any activity concerning legislation or appropriations designed to influence the U.S. Congress or a state legislature; and

B. Exception. If permitted by applicable federal law, regulations, requirements, or guidance, such lobbying activities described above may be undertaken through the Recipient's or Subrecipient's proper official channels.

C. Political Activity. The Recipient agrees to comply with:

- I. The Hatch Act, 5 U.S.C. chapter 15, which limits the political activities of state and local government agencies supported in whole or in part with federal assistance, including the political activities of state and local government officers and employees whose principal governmental employment activities are supported in whole or in part with federal assistance;
- II. U.S. Office of Personnel Management regulations, "Political Activity of State or Local Officers or Employees," 5 C.F.R. part 151; and
- III. 49 U.S.C. § 5323(l)(2) and 23 U.S.C. § 142(g), which limits the applicability of the Hatch Act, as follows:
 - a. The Hatch Act does not apply to nonsupervisory employees of a public transportation system, or any other agency or entity performing related functions, based upon the Award of federal assistance under 49 U.S.C. chapter 53 or 23 U.S.C. § 142(a)(2); but
 - b. Notwithstanding the preceding section 4(e)(3)(ii) of this Master Agreement, the Hatch Act does apply to a nonsupervisory employee if imposed for a reason other than the Award of federal assistance to its employer under 49 U.S.C. chapter 53 or 23 U.S.C. § 142(a)(2).

D. Lobbying and Disclosure Certification

This certification is a material representation of fact upon which reliance was placed when this transaction was made or entered into. Submission of this certification is a prerequisite for making or entering into this transaction imposed by 31 U.S.C. § 1352 (as amended by the Lobbying Disclosure Act of 1995). Any person who fails to file the required certification shall be subject to a civil penalty of not less than \$10,000 and not more than \$100,000 for each such failure.

The undersigned certifies or affirms the truthfulness and accuracy of the contents of the statements submitted on or with this certification and understands that the provisions of 31 U.S.C. Section 3801, et seq., are applicable thereto.

Name of Company	Printed Name of Person Completing Form
Date	Signature

Awards Exceeding \$150,000

The Recipient agrees to comply with the regulations within the Clean Air Act (42 U.S.C. §§ 7401 - 7671q.) and the Federal Water Pollution Control Act (33 U.S.C. §§ 1251 - 1388), as amended. Contracts and subgrants of amounts in excess of \$150,000 must contain a provision that requires the non-federal award to agree to comply with all applicable standards, orders or regulations issued pursuant to the Clean Air Act (42 U.S.C. §§ 7401 - 7671q) and the Federal Water Pollution Control Act as amended (33 U.S.C. §§ 1251 - 1388). Violations must be reported to the 64 Federal awarding agency and the Regional Office of the Environmental Protection Agency (EPA).

State of Texas Procurement Contract Clauses

State of Texas - Procurement Types Summary:

All Texas-Assisted Third-Party Contracts and Subcontracts

1. Debarment
2. Family Code Child Support Obligation Certification
3. Debts and Delinquencies Affirmations
4. Disaster Recovery Plan
5. Disclosure of Prior State Employment
6. Entities that Boycott Israel
7. Federal Executive Order 13224 Excluded Parties
8. False Statements
9. Financial Participation Prohibited Affirmation
10. Foreign Terrorist Organizations
11. Disaster Relief Contract Violation
12. Public Information Act
13. Signature Authority
14. State Auditor's Right to Audit
15. Suspension and Debarment
16. Assignment
17. Contracting Information Responsibilities
18. Human Trafficking Prohibition
19. Energy Company Boycotts
20. Firearm Entities and Trade Association Discrimination

1. 34 TAC §20.585 Debarment

The Recipient agrees that The State of Texas, in order to protect the interests of the state may:

- A. Conduct an investigation upon a complaint regarding a contractor's acts and omissions in procurement or performance of that contract where the complaint may constitute cause for debarment;
- B. Cancel one or more of the contractor's active or pending contracts upon a complaint regarding the contractor's acts and omissions in procurement or performance of that contract where the complaint may constitute cause for debarment;
- C. Assess actual damages and costs incurred due to contractor's failure to perform as specified in the contract;
- D. Debar a contractor for a specified period of time; and
- E. Take any other action authorized by law.

2. §231.006 Family Code Child Support Obligation Certification

Under Section 231.006(d) of the Texas Family Code, the Sub-recipient certifies that the individual or business entity named in this Agreement is not ineligible to receive the specified GRANT and acknowledges that this Agreement may be terminated and payment or grant funds may be withheld if this certification is inaccurate.

3. §2252.903 Gov't Code Debts and Delinquencies Affirmations

Sub-recipient agrees that any payments due it under the Agreement shall be applied toward any debt or delinquency that is owed to the State of Texas.

4. §444.190 Gov't Code Disaster Recovery Plan

In accordance with 13 TAC (Texas Administrative Code) §6.94(a)(9), Sub-recipient shall provide descriptions of its business continuity and disaster recovery plans

5. §2254.033 Gov't Code Disclosure of Prior State Employment

In accordance with Section 2254.033 of the Texas Government Code, relating to consulting services, RESPONDENT certifies that it does not employ an individual who has been employed by TxDOT or another agency at any time during the two years preceding the submission of the Response or, in the alternative, RESPONDENT has disclosed in its Response the following:

- A. The nature of the previous employment with TxDOT or the other agency;
- B. The date the employment was terminated; and
- C. The annual rate of compensation for the employment at the time of its termination.

6. §2271.001 Gov't Code Entities that Boycott Israel

Pursuant to Section 2271.001 of the Texas Government Code, Sub-recipient certifies that either:

- A. It meets an exception criterion under Section 2271.002, or
- B. It does not boycott Israel and will not boycott Israel during the term of this Agreement. Sub-recipient shall in a writing to TxDOT state any fact(s) that make it exempt from the boycott certification.

7. Federal Executive Order 13224 Excluded Parties

Sub-recipient certifies that it is not listed on the prohibited vendors list authorized by Executive Order 13224, Blocking Property and Prohibiting Transactions with Persons Who Commit, Threaten to Commit, or Support Terrorism”, published by the United States Department of the Treasury, Office of Foreign Assets Control.

8. §2155.077(a)(2) Gov't Code False Statements

Sub-recipient represents and warrants that all statements and information prepared and submitted in this document are current, complete, true and accurate. Submitting a false statement or material misrepresentation made during the performance of a contract is a material breach of contract and may void this agreement.

9. §2155.004 Gov't Code Financial Participation Prohibited Affirmation

Under Section 2155.004(b) of the Texas Government Code, Sub-recipient certifies that the individual or business entity named in this Agreement is not ineligible to receive the specified agreement/GRANT and acknowledges that this agreement may be terminated, and payment withheld if this certification is inaccurate.

10. §2252.152 Gov't Code Foreign Terrorist Organizations

Sub-recipient represents and warrants that is not engaged in business with Iran, Sudan, or a foreign terrorist organization as prohibited by Section 2252.152 of the Texas Government Code.

11. §2155.006 and 2261.053 Gov't Code Prior Disaster Relief Contract Violation

Under Sections 2155.006 and 2261.053 of the Texas Government Code, the Sub-recipient certifies that the individual or business entity named in this Agreement is not ineligible to receive the specified agreement/GRANT and acknowledges that this agreement may be terminated and payment withheld if this certification is inaccurate.

12. Chapter 552, Gov't Code and §2252.907 Gov't Code Public Information Act

Information, documentation, and other material in connection with this Agreement may be subject to public disclosure pursuant to Chapter 552 of the Texas Government Code (the “Public Information Act”). In accordance with Section 2252.907 of the Texas Government Code, the Sub-recipient is required to make any information created or exchanged with the State pursuant to the Agreement and not otherwise excepted from disclosure under the Texas Public Information Act, available in a format that is

accessible by the public at no additional charge to the State.

13. §2252.0012 Gov't Code Signature Authority

The Sub-recipient represents and warrants that the individual executing this Agreement is authorized to sign this Agreement on behalf of the Sub-recipient and to bind the Sub-recipient.

14. §2262.154 Gov't Code State Auditor's Right to Audit

The state auditor may conduct an audit or investigation of any entity receiving funds from the state directly under the contract or indirectly through a subcontract under the contract. The acceptance of funds directly under the contract or indirectly through a subcontract under the contract acts as acceptance of the authority of the state auditor, under the direction of the legislative audit committee, to conduct an audit or investigation in connection with those funds. Under the direction of the legislative audit committee, an entity that is the subject of an audit or investigation by the state auditor must provide the state auditor with access to any information the state auditor considers relevant to the investigation or audit.

15. §2155.077 Gov't Code Suspension and Debarment

Sub-recipient certifies that it and its principals are not suspended or debarred from doing business with the State of Texas or federal government as listed on the State of Texas Debarred Vendor List as maintained by the Texas Comptroller of Public Accounts and the System for Award Management (SAM) maintained by the General Services Administration.

16. §2262.056 (b) Gov't Code Assignment

Sub-recipient shall not assign its rights under the Agreement or delegate the performance of its duties under the Agreement without prior written approval from the TxDOT. Any attempted assignment in violation of this provision is void and without effect.

17. §552.372 Gov't Code Contracting Information Responsibilities

In accordance with Section 552.372 of the Texas Government Code, Sub-recipient agrees to:

- A. preserve all contracting information related to the Agreement as provided by the records retention requirements applicable to TxDOT for the duration of the Agreement,
- B. promptly provide to TxDOT any contracting information related to the Agreement that is in the custody or possession of the Sub-recipient on request of TxDOT, and
- C. on termination or expiration of the contract, either provide at no cost to TxDOT all contracting information related to the Agreement that is in the custody or possession of the Sub-recipient or preserve the contracting information related to the Agreement as provided by the records retention requirements applicable to TxDOT. Except as provided by Section 552.374(c) of the Texas Government Code, the requirements of Subchapter J, Chapter 552, Government Code, may apply to the Agreement and the Sub-recipient agrees that the Agreement can be terminated if the Sub-recipient knowingly or intentionally fails to comply with a requirement of that subchapter.

18. §2155.0061 Gov't Code Human Trafficking Prohibition

Under Section 2155.0061 of the Texas Government Code, the Sub-recipient certifies that the individual or business entity named in the Agreement is not ineligible to receive the specified Agreement/GRANT and acknowledges that this Agreement may be terminated and payment withheld if this certification is inaccurate.

19. §2274.002 Energy Company Boycotts

If Respondent is required to make a verification pursuant to Section 2274.002 of the Texas Government Code, Respondent verifies that Respondent does not boycott energy companies and will not boycott energy companies during the term of the Contract. If Respondent does not make that verification, Respondent must so indicate in its Response and state why the verification is not required.

20. §2274 Firearm Entities and Trade Association Discrimination

If Respondent is required to make a verification pursuant to Section 2274.002 of the Texas Government Code, Respondent verifies that it (1) does not have a practice, policy, guidance, or directive that discriminates against a firearm entity or firearm trade association and (2) will not discriminate during the term of the contract against a firearm entity or firearm trade association. If Respondent does not make that verification, Respondent must so indicate in its Response and state why the verification is not required.

21. §2252.908, 2254.032, 2261.252(b) No Conflict of Interest

Respondent represents and warrants that the provision of goods and services or other performance under the contract will not constitute an actual or potential conflict of interest or reasonably create an appearance of impropriety.

Certification to Purchaser

1. The undersigned vendor certifies that the manufactured good(s) furnished will meet or exceed the specifications, and/or that services rendered will comply with the terms of the solicitation or contract.
2. The undersigned vendor certifies that it has read all of the bid, proposal, or contract documents and agrees to abide by the terms, certifications, and conditions thereof.

Name of Company:

Address:

Telephone:

SS# or Tax ID#:

Printed Name of Person Completing Form:

Signature

Date:

Description of Commodity Service:

Disadvantaged Business Enterprise Information

Type of Organization (check the application type of organization)

- Sole Proprietorship General Proprietorship Corporation Limited Partnership Limited Proprietorship

Is your firm a DBE? Yes No

If yes, what type?

Third Party Procurement Contract Provisions

Third Party Procurement Contracting Provisions

Select the additional third-party procurement contracting provisions based on the type of solicitation you're procuring:

**Procurements cannot be combined. Example: Construction procurement and Rolling Stock procurement, use separate PTN 130s for each.*

- 1. Construction Related Clauses**
 - Federal and State
 - State Clauses

- 2. Rolling Stock Related Clauses**
 - Federal and State
 - State Clauses

- 3. Professional Services / Architectural Engineering**
 - Federal and State
 - State Clauses

- 4. Materials & Supplies Related Clauses**
 - Federal and State
 - State Clauses

- 5. Operations / Management Related Clauses**
 - Federal and State
 - State Clauses

3a. Federal Professional Services Architectural & Engineering Related Clauses

A. Rights in Data and Copyrights (R&D)

B. Patent Rights and Rights in Data

C. Termination Clause: (Select One)

- Termination for Convenience or Default (Architect and Engineering)
- Termination for Convenience (Professional or Transit Service Contracts)

For Architectural and Engineering

A. Rights in Data and Copyrights

- I. Definition of "Subject Data." As used in this section, "subject data" means recorded information, whether or not copyrighted, that is delivered or specified to be delivered as required by the Underlying Agreement. Examples of subject data include, but are not limited to computer software, standards, specifications, engineering drawings and associated lists, process sheets, manuals, technical reports, catalog item identifications, and related information, but do not include financial reports, cost analyses, or other similar information used for performance or administration of the Underlying Agreement.
- II. General Federal Restrictions. The following restrictions apply to all subject data first produced in the performance of the Underlying Agreement:
 - a. Prohibitions. The Recipient may not publish or reproduce any subject data, in whole, in part, or in any manner or form, or permit others to do so.
 - b. Exceptions. The prohibitions do not apply to publications or reproductions for the Recipient's own internal use, an institution of higher learning, the portion of subject data that the Federal Government has previously released or approved for release to the public, or the portion of data that has the Federal Government's prior written consent for release.
- III. Federal Rights in Data and Copyrights. The Recipient agrees that:
 - a. General. It must provide a license to its subject data to the Federal Government that is royalty-free, non-exclusive, and irrevocable. The Federal Government's license must permit the Federal Government to reproduce, publish, or otherwise use the subject data or permit other entities or individuals to use the subject data provided those actions are taken for Federal Government purposes; and
 - b. U.S. DOT Public Access Plan – Copyright License. The Recipient grants to U.S. DOT a worldwide, non-exclusive, non-transferable, paid-up, royalty free copyright license, including all rights under copyright, to any and all Publications and Digital Data Sets as such terms are defined in the U.S. DOT Public Access plan, resulting from scientific research funded either fully or partially by this funding agreement. The Recipient herein acknowledges that the above copyright license grant is first in time to any and all other grants of a copyright license to such Publications and/or Digital Data Sets, and that U.S. DOT shall have priority over any other claim of exclusive copyright to the same.
- IV. Special Federal Rights in Data for Research, Development, Demonstration, Deployment, Technical Assistance, and Special Studies Programs. In general, FTA's purpose in providing federal assistance for a research, development, demonstration, deployment, technical assistance, or special studies program is to increase transportation knowledge, rather than limit the benefits of the Award to the Recipient and its Third-Party Participants. Therefore, the Recipient agrees that:
 - a. Publicly Available Report. When an Award providing federal assistance for any of the programs described above is completed, it must provide a report of the Underlying Agreement that FTA may publish or make available for publication on the Internet.
 - b. Other Reports. It must provide other reports related to the Award that FTA may request.
 - c. Availability of Subject Data. FTA may make available its copyright license to the subject data, and a copy of the subject data

- to any FTA Recipient or any Third-Party Participant at any tier, except as the Federal Government determines otherwise in writing.
- d. Identification of Information. It must identify clearly any specific confidential, privileged, or proprietary information submitted to FTA
 - e. Incomplete. If the Award is not completed for any reason whatsoever, all data developed with federal assistance for the Award becomes subject data and must be delivered as the Federal Government may direct.
 - f. Exception. This section does not apply to an adaptation of any automatic data processing equipment or program that is both for the Recipient's use and acquired with FTA capital program assistance.
- V. License Fees and Royalties. Consistent with the applicable U.S. DOT Common Rules, the Recipient agrees that license fees and royalties for patents, patent applications, and inventions produced with federal assistance provided through the Underlying Agreement are program income and must be used in compliance with federal applicable requirements.
- VI. Hold Harmless. Upon request by the Federal Government, the Recipient agrees that if it intentionally violates any proprietary rights, copyrights, or right of privacy, and if its violation under the preceding section occurs from any of the publication, translation, reproduction, delivery, use or disposition of subject data, then it will indemnify, save, and hold harmless the Federal Government against any liability, including costs and expenses of the Federal Government's officers, employees, and agents acting within the scope of their official duties. The Recipient will not be required to indemnify the Federal Government for any liability described in the preceding sentence, if the violation is caused by the wrongful acts of federal officers, employees or agents, or if indemnification is prohibited or limited by applicable state law.
- VII. Restrictions on Access to Patent Rights. Nothing in this section of this Master Agreement pertaining to rights in data either implies a license to the Federal Government under any patent or may be construed to affect the scope of any license or other right otherwise granted to the Federal Government under any patent.
- VIII. Data Developed Without Federal Assistance or Support. The Recipient agrees that in certain circumstances it may need to provide to FTA data developed without any federal assistance or support. Nevertheless, this section generally does not apply to data developed without federal assistance, even though that data may have been used in connection with the Award. The Recipient agrees that the Federal Government will not be able to protect data developed without federal assistance from unauthorized disclosure unless that data is clearly marked "Proprietary," or "Confidential."
- IX. Requirements to Release Data. The Recipient understands and agrees that the Federal Government may be required to release data and information that the Recipient submits to the Federal Government as required under:
- a. The Freedom of Information Act (FOIA), 5 U.S.C. § 552;
 - b. The U.S. DOT Common Rules;
 - c. The U.S. DOT Public Access Plan, which provides that the Recipient agrees to satisfy the reporting and compliance requirements as set forth in the U.S. DOT Public Access plan, including, but not limited to, the submission and approval of a Data Management Plan, the use of Open Researcher and Contributor ID (ORCID) numbers, the creation and maintenance of a Research Project record in the Transportation Research Board's (TRB) Research in Progress (RiP) database, and the timely and complete submission of all required publications and associated digital data sets as such terms are defined in the DOT Public Access plan. Additional information about how to comply with the requirements can be found at <http://ntl.bts.gov/publicaccess/howtocomply.html>; or
 - d. Other federal laws, regulations, requirements, and guidance concerning access to records pertaining to the Award, the accompanying Underlying Agreement, and any Amendments thereto.

B. Patent Rights and Rights in Data

Intellectual Property Rights

This Project is funded through a Federal award with FTA for experimental, developmental, or research work purposes. As such, certain Patent Rights and Data Rights apply to all subject data first produced in the performance of this Contract. The Contractor shall grant the Agency intellectual property access and licenses deemed necessary for the work performed under this Contract and in accordance with the requirements of 37 C.F.R. part 401, "Rights to Inventions Made by Nonprofit Organizations and Small Business Firms Under Government Grants, Contracts and Cooperative Agreements," and any implementing regulations issued by FTA or U.S. DOT.

The terms of an intellectual property agreement and software license rights will be finalized prior to execution of this Contract and

shall, at a minimum, include the following restrictions:

Except for its own internal use, the Contractor may not publish or reproduce subject data in whole or in part, or in any manner or form, nor may the Contractor authorize others to do so, without the written consent of FTA, until such time as FTA may have either released or approved the release of such data to the public. This restriction on publication, however, does not apply to any contract with an academic institution.

For purposes of this Contract, the term "subject data" means recorded information whether or not copyrighted, and that is delivered or specified to be delivered as required by the Contract. Examples of "subject data" include, but are not limited to computer software, standards, specifications, engineering drawings and associated lists, process sheets, manuals, technical reports, catalog item identifications, and related information, but do not include financial reports, cost analyses, or other similar information used for performance or administration of the Contract.

1. The Federal Government reserves a royalty-free, non-exclusive and irrevocable licenses to reproduce, publish, or otherwise use, and to authorize others to use for "Federal Government Purposes," any subject data or copyright described below. For "Federal Government Purposes," means use only for the direct purposes of the Federal Government. Without the copyright owner's consent, the Federal Government may not extend its Federal license to any other party.
 - a. Any subject data developed under the Contract, whether or not a copyright has been obtained; and
 - b. Any rights of copyright purchased by the Contractor using Federal assistance in whole or in part by the FTA.
2. Unless FTA determines otherwise, the Contractor performing experimental, developmental, or research work required as part of this Contract agrees to permit FTA to make available to the public, either FTA's license in the copyright to any subject data developed in the course of the Contract, or a copy of the subject data first produced under the Contract for which a copyright has not been obtained. If the experimental, developmental, or research work, which is the subject of this Contract, is not completed for any reason whatsoever, all data developed under the Contract shall become subject data as defined herein and shall be delivered as the Federal Government may direct.
3. Unless prohibited by state law, upon request by the Federal Government, the Contractor agrees to indemnify, save, and hold harmless the Federal Government, its officers, agents, and employees acting within the scope of their official duties against any liability, including costs and expenses, resulting from any willful or intentional violation by the Contractor of proprietary rights, copyrights, or right of privacy, arising out of the publication, translation, reproduction, delivery, use, or disposition of any data furnished under that contract. The Contractor shall not be required to indemnify the Federal Government for any such liability arising out of the wrongful act of any employee, official, or agents of the Federal Government.
4. Nothing contained in this clause on rights in data shall imply a license to the Federal Government under any patent or be construed as affecting the scope of any license or other right otherwise granted to the Federal Government under any patent.
5. Data developed by the Contractor and financed entirely without using Federal assistance provided by the Federal Government that has been incorporated into work required by the underlying Contract is exempt from the requirements herein, provided that the Contractor identifies those data in writing at the time of delivery of the Contract work.
6. The Contractor agrees to include these requirements in each subcontract for experimental, developmental, or research work financed in whole or in part with Federal assistance.

C. Termination Clauses

Termination for Convenience (Professional or Transit Service Contracts)

The Agency, by written notice, may terminate this contract, in whole or in part, when it is in the Agency's interest. If this contract is terminated, the Agency shall be liable only for payment under the payment provisions of this contract for services rendered before the effective date of termination.

Professional Services / A&E Certification

The undersigned vendor certifies to abide by these clauses and include the following clauses in each subcontract financed in whole or in part with Federal Transit Administration (FTA) funds. Vendors are certifying by reference the entire list FTA's current fiscal year Certifications and Assurances (for fiscal year 2024), and shall download at:

<https://www.transit.dot.gov/funding/grantee-resources/certifications-and-assurances/certifications-assurances>.

Name of Company	Printed Name of Person Completing Form
Date	Signature

3b. State of Texas Required Clauses: A&E

- A. Buy Texas Affirmation
- B. RP8 E-Verify Program
- C. Anti-Trust Affirmation
- D. Standard of Care for Architectural and Engineering Contracts
- E. Code Indemnification
- F. Dispute Resolution Contract for Professional Services of Architect, Engineer, or Surveyor
- G. Professional Services Procurement Act

A. §2155.4441 Gov't Code Buy Texas Affirmation

In accordance with Section 2155.4441 of the Texas Government Code, Sub-recipient agrees that during the performance of a contract for services it shall purchase products and material produced in Texas when they are available at a price and time comparable to products and materials produced outside this state.

B. Executive Order No. RP8 E-Verify Program

Sub-recipient certifies that for contracts for services, Sub-recipient shall utilize the U.S Department of Homeland Security's E-Verify system during the term of the agreement to determine the eligibility of:

- I. All persons employed by the Sub-recipient to perform duties within Texas; and
- II. All persons, including subcontractors, assigned by the Sub-recipient to perform work pursuant to the Agreement within the United States of America.

C. §2155.005 Texas Government Code Anti-Trust Affirmation

The undersigned affirms under penalty of perjury of the laws of the State of Texas that

- I. In connection with this Response, neither I nor any representative of the Respondent have violated any provision of the Texas Free Enterprise and Antitrust Act, Tex. Bus. & Comm. Code Chapter 15;
- II. In connection with this Response, neither I nor any representative of the Respondent have violated any federal antitrust law; and
- III. Neither I nor any representative of the Respondent have directly or indirectly communicated any of the contents of this Response to a competitor of the Respondent or any other company, corporation, firm, partnership or individual engaged in the same line of business as the Respondent.

D. §2254.0031 Gov't Code and §271.904(a)-(e) and (g) Tex Local Gov't Code Standard of Care for Architectural and Engineering Contracts

Pursuant to Section 2254.0031 of the Texas Government Code, which incorporates by reference Section 271.904(d) of the Texas Local Government Code, Sub-recipient shall perform services

- I. With professional skill and care ordinarily provided by competent engineer or architect practicing under the same or similar circumstances and professional license, and
- II. As expeditiously as is prudent considering the ordinary professional skill and care of a competent engineer or architect.

E. §2254.0031 Gov't Code and §271.904 (a)-(e) and (g) Tex Local Govt Code Indemnification

Sub-recipient shall indemnify and hold harmless the State of Texas and TxDOT, and/or their officers, agents, employees, representatives, contractors, assignees, and/or designees from any and all liability, actions, claims, demands, or suits and all related damages, costs, attorneys fees, and expense to the extent caused by, arising out of, or resulting from any acts of negligence, intentional torts, willful misconduct, personal injury, or damage to property, and/or otherwise related to Sub-recipient's performance and/or failures to pay a subcontractor or supplier by the Sub-recipient or its agents, employees, subcontractors, order fulfillers, consultants under contract to sub-recipient, or any other entity over which the contractor exercises control, or suppliers of sub-contractors in the execution or performance of the Agreement. The defense shall be coordinated by Sub-recipient with the Office of the Texas Attorney General when Texas state agencies are named defendants in any lawsuit and Sub-recipient may not agree to any settlement without first obtaining the concurrence from the Office of the Texas Attorney General. Sub-recipient and TxDOT agree to furnish timely written notice to each other of any such claim.

F. §2254.004 Gov't Code Dispute Resolution Contract for Professional Services of Architect, Engineer, or Surveyor

The Recipient will comply with Texas Government Code, Section 2260.002, the dispute resolution process provided for in Chapter 2260 of the Texas Government Code and set forth below in subsections (a)-(d) shall be used by the parties to attempt to resolve all disputes arising under the agreement. In accordance with the Texas Civil Practice and Remedies Code, Section 114.005, the parties agree claims encompassed by Texas Government Code, Section 2260.002(3) and Texas Civil Practice and Remedies Code Section 114.002 shall be governed by the dispute resolution process set forth below in subsections (a)-(d).

- I. Notwithstanding Texas Government Code Chapter 2260.002 (3) and Chapter 114.12 and any other statute or applicable law, if the Sub-recipient's claim for breach of contract cannot be resolved by the parties in the ordinary course of business, Sub-

recipient may make a claim against Agency for breach of contract and the Agency may assert a counterclaim against Sub-recipient as is contemplated by Texas Government Code Chapter 2260, Subchapter B. In such event, Sub-recipient must provide written notice to Agency of a claim for breach of the agreement not later than the 180th day after the date of the event giving rise to the claim. The notice must state with particularity:

- a. the nature of the alleged breach;
 - b. the amount the Sub-recipient seeks as damages; and
 - c. the legal theory of recovery.
- II. The chief administrative officer, or if designated in the Agreement another officer of TxDOT, shall examine the claim and any counterclaim and negotiate with Sub-recipient in an effort to resolve them. The negotiation must begin no later than the 120th day after the date the claim is received, as is contemplated by Texas Government Code, Chapter 2260, Section 2260.052.
- III. If the negotiation under paragraph. Above results in the resolution of some disputed issues by agreement or in a settlement, the parties shall reduce the agreement or settlement to writing and each party shall sign the agreement or settlement. A partial settlement or resolution of a claim does not waive a party's rights under this Agreement as to the parts of the claim that are not resolved.
- IV. If a claim is not entirely resolved under paragraph (b) above, on or before the 270th day after the date the claim is filed with TxDOT, unless the parties agree in writing to an extension of time, the parties may agree to mediate a claim made under this dispute resolution procedure. This dispute resolution procedure is Sub-provider's sole and exclusive process for seeking a remedy or an alleged breach of contract by TxDOT if the parties are unable to resolve their dispute as described in this section.
- V. Nothing in this Agreement shall be construed as a waiver of the state's or TxDOT's sovereign immunity. This Agreement shall not constitute or be construed as a waiver of any of the privileges, rights, defenses, remedies, or immunities available to the State of Texas. The failure to enforce, or any delay in the enforcement, of any privileges, rights, defenses, remedies, or immunities available to the State of Texas under this Agreement or under applicable law shall not constitute a waiver of such privileges, rights, defenses, remedies, or immunities, or be considered as a basis for estoppel. TxDOT does not waive any privileges, rights, defenses, or immunities available to TxDOT by entering into this Agreement or by its conduct or by the conduct of any representatives of TxDOT, prior to or subsequent to entering into this Agreement.
- VI. Compliance with the dispute resolution process provided for in Texas Government Code, Chapter 2260, subchapter B and incorporated by reference in subsection (a)-(d) above is a condition precedent to the Sub-recipient:
- a. filing suit pursuant to Chapter 114 of the Civil Practice and Remedies Code; or
 - b. initiating a contested case hearing pursuant to subchapter C of Chapter 2260 of the Texas Government Code.

G. §2254.004 Gov't Code Professional Services Procurement Act

In procuring architectural or engineering services, a government entity shall:

- I. First select the most highly qualified provider of those services on the basis of demonstrated competence and qualifications; and then attempt to negotiate with that provider a contract.
- II. At a fair and reasonable price.

Professional Services / A&E Certification

The undersigned vendor certifies to abide by these clauses and include the following clauses in each subcontract financed in whole or in part with State of Texas funds.

Name of Company	Printed Name of Person Completing Form
Date	Signature